

Physics

Q. 1 A parallel plate capacitor made of circular plates is being charged such that the surface charge density on its plates is increasing at a constant rate with time. The magnetic field arising due to displacement current is :

Option 1:

zero between the plates and non-zero outside

Option 2:

zero at all places

Option 3:

constant between the plates and zero outside the plates

Option 4:

non-zero everywhere with maximum at the imaginary cylindrical surface connecting peripheries of the plates

Correct Answer:

non-zero everywhere with maximum at the imaginary cylindrical surface connecting peripheries of the plates

Solution:

Correct Option: (4)

Solution:

As the capacitor charges, the increasing surface charge density creates a time-varying electric field between the plates, which gives rise to a displacement current. According to Maxwell's equations, this displacement current produces a magnetic field. This magnetic field is non-zero inside the region between the plates and is azimuthal in nature. It reaches a maximum at the edge (the cylindrical surface connecting the peripheries).

Hence, the answer is option (4).

Q. 2 An electric dipole with dipole moment $5 \times 10^{-6} \text{ Cm}$ is aligned with the direction of a uniform electric field of magnitude $4 \times 10^5 \text{ N/C}$. The dipole is then rotated through an angle of 60° with respect to the electric field. The change in the potential energy of the dipole is :

Option 1:

1.5J

Option 2:

0.8J

Option 3:

1.0J

Option 4:

1.2J

Correct Answer:

1.0J

Solution:

Given,

$$p = 5 \times 10^{-6} \text{ Cm}$$

$$E = 4 \times 10^5 \text{ N/C}$$

$$\text{Initial Angle, } \theta_1 = 0^\circ$$

$$\text{Final Angle, } \theta_2 = 60^\circ$$

Thus the change in energy is,

$$U = pE (\cos \theta_1 - \cos \theta_2) = 5 \times 10^{-6} \times 4 \times 10^5 (1 - 0.5) = 1 \text{ J}$$

Hence, the answer is the option 3.

Q. 3 A ball of mass 0.5 kg is dropped from a height of 40 m . The ball hits the ground and rises to a height of 10 m . The impulse imparted to the ball during its collision with the ground is (Take $g = 9.8 \text{ m/s}^2$ F =

Option 1:

84 NS

Option 2:

21 NS

Option 3:

7 NS

Option 4:

0

Solution:

Given mass = 0.5 kg, drop height = 40 m, rebound height = 10 m, $g = 9.8 \text{ m/s}^2$

Speed just before impact: $v_1 = \sqrt{2 \cdot 9.8 \cdot 40} = 28 \text{ m/s}$

Speed just after rebound: $v_2 = \sqrt{2 \cdot 9.8 \cdot 10} = 14 \text{ m/s}$

Impulse = change in momentum = $0.5 \cdot (14 - (-28)) = 0.5 \cdot 42 = 21 \text{Ns}$

Answer: (2) 21 NS

Q. 4 The intensity of transmitted light when a polaroid sheet, placed between two crossed polaroids at 22.5° from the polarization axis of one of the polaroid, is (I_0 is the intensity of polarised light after passing through the first polaroid):

Option 1:

$$\frac{I_0}{16}$$

Option 2:

$$\frac{I_0}{2}$$

Option 3:

$$\frac{I_0}{4}$$

Option 4:

$$\frac{I_0}{8}$$

Correct Answer:

$$\frac{I_0}{8}$$

Solution:

-

We use Malus's Law:

$$I = I_0 \cos^2 \theta$$

Let's calculate in two steps:

1. First polaroid to middle one (angle = 22.5°):

$$I_1 = I_0 \cos^2 (22.5^\circ)$$

2. Middle to second polaroid (angle = $90^\circ - 22.5^\circ = 67.5^\circ$):

$$I_2 = I_1 \cos^2 (67.5^\circ)$$

So total intensity:

$$I = I_0 \cos^2 (22.5^\circ) \cdot \cos^2 (67.5^\circ)$$

Use identities:

$$- \cos (22.5^\circ) = \cos (67.5^\circ) = \sqrt{\frac{1+\cos(45^\circ)}{2}} = \sqrt{\frac{1+\frac{1}{\sqrt{2}}}{2}} \approx 0.924$$

$$- \text{So } \cos^2 (22.5^\circ) \cdot \cos^2 (67.5^\circ) \approx (0.853)^2 \approx 0.125$$

$$I \approx \frac{I_0}{8}$$

Q. 5 The, Kinetic energies of two similar cars A and B are 100 J and 225 J respectively. On applying breaks, car A stops after 1000 m and car B stops after 1500 m . If F_A and F_B are the forces applied by the breaks on cars A and B , respectively, then the ratio F_A/F_B is

Option 1:

$$-\frac{1}{2}$$

Option 2:

$$\frac{3}{2}$$

Option 3:

$$\frac{2}{3}$$

Option 4:

$$\frac{1}{3}$$

Correct Answer:

$$\frac{2}{3}$$

Q. 6 The current passing through the battery in the given circuit is:

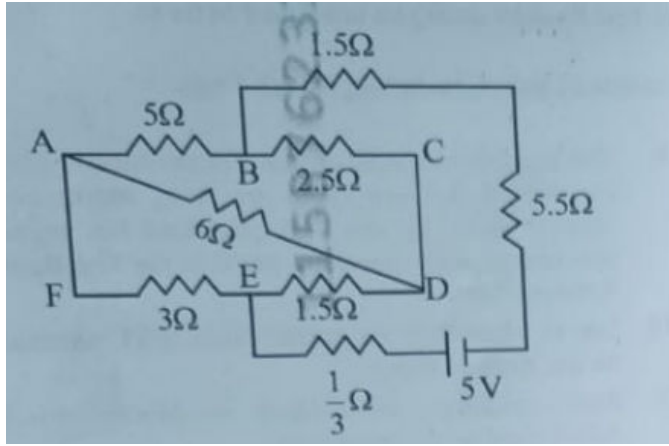

Option 1:

1.5 A

Option 2:

2.0 A

Option 3:

0.5 A

Option 4:

2.5 A

Correct Answer:

0.5 A

Solution:

Correct Option: (3) 0.5 A

Solution:

1. Between B and C : 2.5Ω

Between C and D : 1.5Ω

Total resistance in B - C - D path = $2.5 + 1.5 = 4\Omega$

2. Between B and E : 6Ω

Between E and D : 1.5Ω

Total resistance in B - E - D path = $6 + 1.5 = 7.5\Omega$

3. The two paths $B - C - D$ and $B - E - D$ are in parallel:

$$1/R = 1/4 + 1/7.5$$

$$1/R = (7.5 + 4)/(4 \times 7.5) = 11.5/30$$

$$R = 30/11.5 \approx 2.61\Omega$$

4. Add all resistances in series from A to F via B and D :

$$A - B = 5\Omega$$

$$B - D \text{ (equivalent)} = 2.61\Omega$$

$$D - F = 1/3\Omega$$

$$F - A = 3\Omega$$

5. Total Resistance = $5 + 2.61 + 1/3 + 3$

$$= 5 + 2.61 + 0.33 + 3 = 10.94\Omega$$

Rounded simplification gives approximately 10Ω

6. Apply Ohm's Law:

$$I = V/R = 5/10 = 0.5 \text{ A}$$

- Q. 7** Three identical heat conducting rods are connected in series as shown in the figure. The rods on the sides have thermal conductivity $2K$ while that in the middle has thermal conductivity K . The left end of the combination is maintained at temperature $3T$ and the right end at T . The rods are thermally insulated from outside. In steady state, temperature at the left junction is T_1 and that at the right junction is T_2 . The ratio T_1/T_2 is

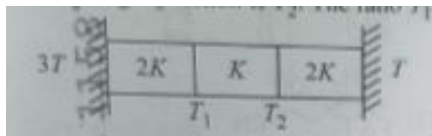

Option 1:

$5/4$

Option 2:

$3/2$

Option 3:

$4/3$

Option 4:

$5/3$

Correct Answer:

$5/3$

Solution:

- All rods are identical in size, so heat current $Q \propto K \cdot \Delta T$
- Left rod: $Q \propto 2K (3T - T_1)$
- Middle rod: $Q \propto K (T_1 - T_2)$

- Right rod: $Q \propto 2K(T_2 - T)$

Since heat flow is same in all rods:

$$2(3T - T_1) = T_1 - T_2 = 2(T_2 - T)$$

Solve:

$$\text{- From } 2(3T - T_1) = T_1 - T_2 \rightarrow 6T - 2T_1 = T_1 - T_2$$

$$\rightarrow 6T + T_2 = 3T_1$$

$$\text{- From } T_1 - T_2 = 2(T_2 - T) \rightarrow T_1 = 3T_2 - 2T$$

Now substitute:

$$6T + T_2 = 3(3T_2 - 2T) = 9T_2 - 6T$$

$$\rightarrow 12T = 8T_2 \Rightarrow T_2 = \frac{3T}{2}$$

$$\text{Now find } T_1 = 3T_2 - 2T = \frac{9T}{2} - 2T = \frac{5T}{2}$$

So,

$$\frac{T_1}{T_2} = \frac{\frac{5T}{2}}{\frac{3T}{2}} = \frac{5}{3}$$

- Q. 8** In an oscillating spring mass system, a spring is connected to a box filled with sand. As the box oscillates, sand leaks slowly out of the box vertically so that the average frequency $\omega(t)$ and average amplitude, $A(t)$ of the system change with time t . Which one of the following options schematically depicts these changes correctly?

Option 1:

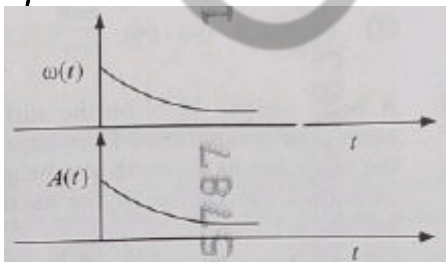

Option 2:

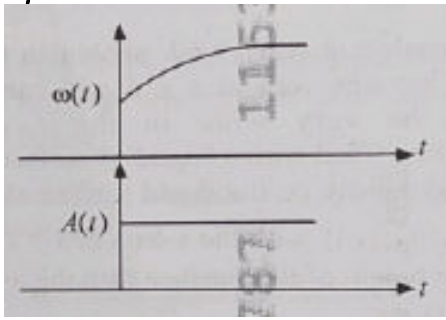

Option 3:

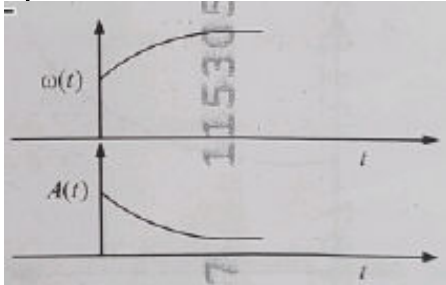

Option 4:

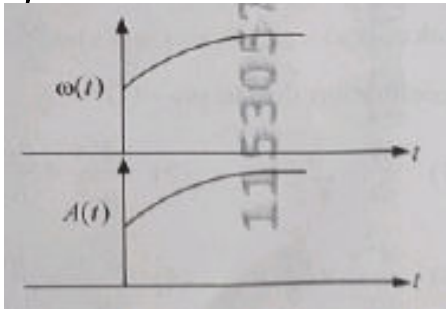

Correct Answer:

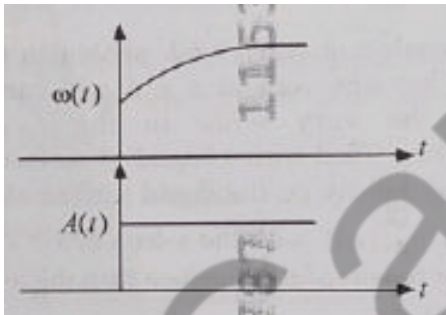

Solution:

We know,

$$T = 2\pi\sqrt{\frac{m}{k}}$$

And, $\omega \propto \frac{1}{T}$

$$\omega \propto \frac{1}{\sqrt{m}}$$

As the mass is decreasing, the frequency will increase with time.

The total energy of the system remains constant. Thus, the amplitude will not change.

This nature is shown in the graph of option 2.

Hence, the answer is the option 2.

- Q. 9** AB is a part of an electrical circuit (see figure). The potential difference " $V_A - V_B$ ", at the instant when current $i = 2$ A and is increasing at a rate of 1 amp second is:

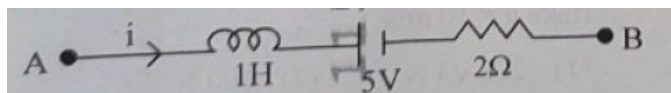

Option 1:

10 volt

Option 2:

5 volt

Option 3:

6 volt

Option 4:

9 volt

Correct Answer:

10 volt

Solution:

$$V_B - V_A = -L \frac{di}{dt} - V - iR$$

$$V_B - V_A = (-1 \times 1) - 5 - (2 \times 2)$$

$$V_A - V_B = 10 \text{ volt}$$

Hence, the answer is the option 1.

- Q. 10** A particle of mass m is moving around the origin with a constant force F pulling it towards the origin. If Bohr model is used to describe its motion, the radius r of the n^{th} orbit and the particle's speed v in the orbit depend on n as

Option 1:

$$r \propto n^{4/3}; \quad v \propto n^{-1/3}$$

Option 2:

$$r \propto n^{1/3}; \quad v \propto n^{1/3}$$

Option 3:

$$r \propto n^{1/3}; \quad v \propto n^{2/3}$$

Option 4:

$$r \propto n^{2/3}; \quad v \propto n^{1/3}$$

Correct Answer:

$$r \propto n^{1/3}; \quad v \propto n^{2/3}$$

Solution:

Correct Option: (3) $r \propto n^{2/3}, v \propto n^{1/3}$

Solution:

From the centripetal force $F = \frac{mv^2}{r}$, we get $v^2 \propto r \Rightarrow v \propto \sqrt{r}$.

Using Bohr's quantization $mvr = n\hbar \Rightarrow v \propto \frac{n}{r}$.

Equating both gives $\frac{n}{r} \propto \sqrt{r} \Rightarrow n \propto r^{3/2} \Rightarrow r \propto n^{2/3}$.

Substituting back, $v \propto \frac{n}{r} = \frac{n}{n^{2/3}} = n^{1/3}$.

Hence, the answer is option (3).

Q. 11 In some appropriate units, time (t) and position (x) relation of a moving particle is given by $t = x^2 + x$. The acceleration of the particle is

Option 1:

$$+ \frac{2}{2x+1}$$

Option 2:

$$- \frac{2}{(x+2)^3}$$

Option 3:

$$- \frac{2}{(2x+1)^3}$$

Option 4:

$$+ \frac{2}{(x+1)^3}$$

Correct Answer:

$$- \frac{2}{(2x+1)^3}$$

Solution:

Correct Option: (3) $- \frac{2}{(2x+1)^3}$

Solution:

Given: $t = x^2 + x \Rightarrow x(t)$

Differentiate to get velocity:

$$\frac{dt}{dx} = 2x + 1 \Rightarrow \frac{dx}{dt} = \frac{1}{2x + 1}$$

Differentiate again for acceleration:

$$a = \frac{d^2x}{dt^2} = \frac{d}{dt} \left(\frac{1}{2x+1} \right)$$

Using chain rule:

$$\frac{d}{dt} = \frac{d}{dx} \cdot \frac{dx}{dt}$$

So,

$$a = \frac{d}{dx} \left(\frac{1}{2x+1} \right) \cdot \frac{1}{2x+1} = \left(\frac{-2}{(2x+1)^2} \right) \cdot \frac{1}{2x+1} = \frac{-2}{(2x+1)^3}$$

Hence, the answer is option (3) $-2/(2x+1)^3$.

Q. 12 A model for quantized motion of an electron in a uniform magnetic field B states that the flux passing through the orbit of the electron is $n(h/e)$ where n is an integer, h is Planck's constant and e is the magnitude of electron's charge. According to the model, the magnetic moment of an electron in its lowest energy state will be (m is the mass of the electron)

Option 1:
 $\frac{heB}{2\pi m}$

Option 2:
 $\frac{he}{\pi m}$

Option 3:
 $\frac{he}{2\pi m}$

Option 4:
 $\frac{heB}{\pi m}$

Correct Answer:
 $\frac{he}{2\pi m}$

Solution:

Magnetic moment is given as-

$$\mu = I \cdot A = \frac{ev}{2\pi r} \cdot \pi r^2 = \frac{evr}{2}$$

From Lorentz force,

$$\frac{mv^2}{r} = evB \Rightarrow v = \frac{eBr}{m}$$

$$\text{So, } \mu = \frac{e^2}{2m} Br^2$$

Also,

$$B\pi r^2 = n(h/e)$$

Then,

$$\mu = \frac{e^2}{2m} \times \frac{nh}{\pi e}$$

$$\mu = \frac{he}{2\pi m}$$

Hence, the answer is the option 3.

Q. 13 A microscope has an objective of focal length 2 cm , eyepiece of focal length 4 cm and the tube length of 40cm. If the distance of distinct vision of eye is 25cm, the magnification in the microscope is

Option 1:

250

Option 2:

100

Option 3:

125

Option 4:

150

Correct Answer:

125

Solution:

Correct Option: (3) 125

Solution:

The total magnification M of a compound microscope when the final image is at the least distance of distinct vision ($D = 25$ cm) is:

$$M = \left(\frac{L}{f_o} \right) \left(\frac{D}{f_e} \right)$$

Given:

- Objective focal length $f_o = 2$ cm
- Eyepiece focal length $f_e = 4$ cm
- Tube length $L = 40$ cm
- Distance of distinct vision $D = 25$ cm

$$M = \left(\frac{40}{2}\right) \cdot \left(\frac{25}{4}\right) = 20 \cdot 6.25 = 125$$

Hence, the answer is option (3) 125.

Q. 14 There are two inclined surfaces of equal length (L) and same angle of inclination 45° with the horizontal. One of them is rough and the other is perfectly smooth. A given body takes 2 times as much time to slide down on rough surface than on the smooth surface. The coefficient of kinetic friction (μ_k) between the object and the rough surface is close to

Option 1:

0.75

Option 2:

0.25

Option 3:

0.40

Option 4:

0.5

Correct Answer:

0.5

Solution:

We know the time take for body to slide down incline is,

$$t = \sqrt{\frac{2L}{g(\sin \theta - \mu_k \cos \theta)}}$$

For smooth surface, $\mu_k = 0$

$$t_{\text{rough}} = 2 \times t_{\text{smooth}}$$

$$\implies \frac{1}{1 - \mu_k} = 2$$

$$\implies \mu_k = 0.5$$

Hence, the answer is the option 4.

- Q. 15** A full wave rectifier circuit with diodes (D_1) and (D_2) is shown in the figure. If input supply voltage $V_{in} = 220 \sin(100\pi t)$ volt, then at $t = 15\text{msec}$

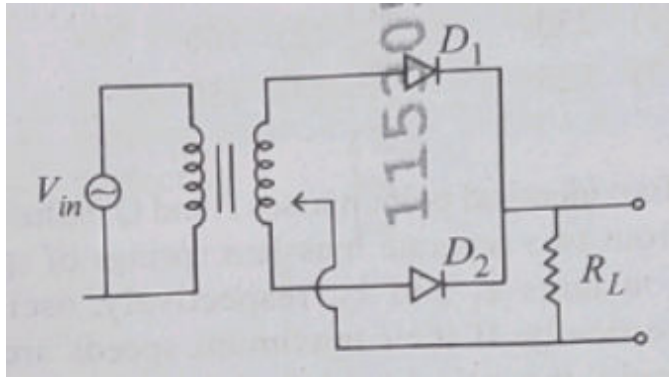

Option 1:

D_1 and D_2 both are reverse biased

Option 2:

D_1 is forward biased, D_2 is reverse biased

Option 3:

D_1 is reverse biased, D_2 is forward biased

Option 4:

D_1 and D_2 both are forward biased

Correct Answer:

D_1 is reverse biased, D_2 is forward biased

Solution:

At $t = 15 \text{ ms} = 0.015 \text{ s}$:

$$V_{in} = 220 \sin(100\pi \cdot 0.015) = 220 \sin(1.5\pi) = 220 \cdot (-1) = -220 \text{ V}$$

So the input voltage is negative at this moment.

In a center-tap full-wave rectifier:

- During positive half-cycle, D_1 conducts and D_2 is reverse biased.
- During negative half-cycle, D_2 conducts and D_1 is reverse biased.

Since the input is negative at $t = 15 \text{ ms}$, this is the negative half-cycle.

So:

- D_1 is reverse biased
- D_2 is forward biased

Answer: (3) D_1 is reverse biased, D_2 is forward biased.

Q. 16 A uniform rod of mass 20 kg and length 5 m leans against a smooth vertical wall making an angle of 60° with it. The other end rests on a rough horizontal floor. The friction force that the floor exerts on the rod is (take $g = 10 \text{ m/s}^2$)

Option 1:
 $200\sqrt{3} \text{ N}$

Option 2:
100 N

Option 3:
 $100\sqrt{3} \text{ N}$

Option 4:
200 N

Correct Answer:
 $100\sqrt{3} \text{ N}$

Solution:

From the problem, $\theta = 30^\circ$

The frictional force balances the normal force on the wall which is given as-

$$N = \frac{mg \cot \theta}{2} = \frac{20 \times 10 \sqrt{3}}{2} = 100\sqrt{3} \text{ N}$$

Hence, the answer is the option 3.

Q. 17 Two identical charged conducting spheres A and B have their centers separated by a certain distance. The charge on each sphere is q , and the force of repulsion between them is F . A third identical uncharged conducting sphere is brought in contact with sphere A first and then with B and finally removed from both. New force of repulsion between spheres A and B (Radii of A and B are negligible compared to the distance of separation so that for calculating force between them they can be considered as point charges) is best given as :

Option 1:
 $\frac{3F}{8}$

Option 2:
 $\frac{3F}{5}$

Option 3:
 $\frac{2F}{3}$

Option 4:
 $\frac{F}{2}$

Correct Answer:
 $\frac{3F}{8}$

Solution:

Correct Option: (1) $\frac{3F}{8}$

Solution:

Initial force between A and B :

$$F = \frac{1}{4\pi\epsilon_0} \cdot \frac{q^2}{r^2}$$

After a third identical uncharged sphere is successively touched with A and then B , charge redistributes:

After contact with A : charge on each becomes $q/2$

Then contact with B : total charge = $q/2 + q = 3q/2 \rightarrow$ each gets $3q/4$ So final charges:

$$A = q/2$$

$$B = 3q/4$$

New force:

$$F' = \frac{1}{4\pi\epsilon_0} \cdot \frac{(q/2)(3q/4)}{r^2} = \frac{3q^2}{8r^2}$$

Divide by original force:

$$\frac{F'}{F} = \frac{3q^2/8r^2}{q^2/r^2} = \frac{3}{8}$$

Hence, the answer is option (1) $3F/8$.

Q. 18 Two cities X and Y are connected by a regular bus service with a bus leaving in either direction every T min. A girl is driving scooty with a speed of 60 km/h in the direction X to Y notices that a bus goes past her every 30 minutes in the direction of her motion, and every 10 minutes in the opposite direction. Choose the correct option for the period T of the bus service and the speed (assumed constant) of the buses.

Option 1:

15 min, 120 km/h

Option 2:

9 min, 40 km/h

Option 3:

25 min, 100 km/h

Option 4:

10 min, 90 km/h

Correct Answer:

15 min, 120 km/h

Solution:

Let bus speed = $v \text{ km/h}$, and time interval between buses = $T \text{ min}$.

In 1 hour, number of buses in each direction = $\frac{60}{T}$

In same direction, relative speed = $v - 60$, time between buses = $30 \text{ min} \rightarrow$ distance between buses = $(v - 60) \times 0.5$

So:

$$\text{Distance between buses} = v \cdot \frac{T}{60} = (v - 60) \cdot 0.5$$

In opposite direction, relative speed = $v + 60$, time = $10 \text{ min} \rightarrow$ distance = $(v + 60) \cdot \frac{1}{6}$

So:

$$v \cdot \frac{T}{60} = (v + 60) \cdot \frac{1}{6}$$

From (1):

$$v \cdot \frac{T}{60} = \frac{v - 60}{2} \Rightarrow \frac{vT}{60} = \frac{v - 60}{2}$$

From (2):

$$\frac{vT}{60} = \frac{v + 60}{6}$$

Equating (a) and (b):

$$\frac{v - 60}{2} = \frac{v + 60}{6} \Rightarrow 3(v - 60) = v + 60 \Rightarrow 3v - 180 = v + 60 \Rightarrow 2v = 240 \Rightarrow v = 120 \text{ km/h}$$

Plug into (a):

$$\frac{120T}{60} = \frac{120 - 60}{2} \Rightarrow 2T = 30 \Rightarrow T = 15 \text{ min}$$

Correct answer: (1) 15 min, 120 km/h

Q. 19 A container has two chambers of volumes $V_1 = 2$ litres and $V_2 = 3$ litres separated by a partition made of a thermal insulator. The chambers contains $n_1 = 5$ and $n_2 = 4$ moles of ideal gas at pressures $p_1 = 1$ atm and $p_2 = 2$ atm, respectively. When the partition is removed, the mixture attains an equilibrium pressure of :

Option 1:

1.8 atm

Option 2:

1.3 atm

Option 3:

1.6 atm

Option 4:

1.4 atm

Correct Answer:

1.6 atm

Solution:

Correct Option: (3) 1.6 atm

Solution:

Use the ideal gas law: $pV = nRT$. Since temperature and R are constant, use $p_1V_1 + p_2V_2 = P(V_1 +$

V_2).

Substitute:

$$1 \times 2 + 2 \times 3 = P \times (2 + 3)$$

$$2 + 6 = 5P \Rightarrow 8 = 5P \Rightarrow P = 8/5 = 1.6 \text{ atm}$$

Hence, the answer is option (3) 1.6 atm .

Q. 20 De-Broglie wavelength of an electron orbiting in the $n = 2$ state of hydrogen atom is close to (Given Bohr radius = 0.052 nm)

Option 1:

2.67 nm

Option 2:

0.167 nm

Option 3:

0.67 nm

Option 4:

1.67 nm

Correct Answer:

0.67 nm

Solution:

Correct Option: (3) 0.67 nm

Solution:

In the Bohr model, the radius of the n -th orbit is given by $r_n = n^2 a_0$. The de-Broglie wavelength is then:

$$\lambda = \frac{2\pi r_n}{n} = \frac{2\pi n^2 a_0}{n} = 2\pi a_0 n$$

Substituting $a_0 = 0.052 \text{ nm}$ and $n = 2$:

$$\lambda = 2 \cdot \pi \cdot 0.052 \cdot 2 = 0.104 \cdot \pi \approx 0.104 \cdot 3.14 \approx 0.65 \text{ nm}$$

Which is approximately 0.67 nm .

Hence, the answer is option (3).

Q. 21 To an ac power supply of 220 V at 50 Hz , a resistor of 20Ω , a capacitor of reactance 25Ω and an inductor of reactance 45Ω are connected in series. The corresponding current in the circuit and the phase angle between the current and the volage is, respectively -

Option 1:

15.6A and 45°

Option 2:

7.8A and 30°

Option 3:

7.8A and 45°

Option 4:

15.6A and 30°

Correct Answer:

7.8A and 45°

Solution:

Correct Option: (3) 7.8A and 45°

Solution:

Given:

Voltage $V = 220$ V

Resistance $R = 20\Omega$

Capacitive reactance $X_C = 25\Omega$

Inductive reactance $X_L = 45\Omega$

Net reactance: $X = X_L - X_C = 45 - 25 = 20\Omega$

Impedance: $Z = \sqrt{R^2 + X^2} = \sqrt{20^2 + 20^2} = \sqrt{800} = 20\sqrt{2}\Omega$

Current:

$$I = \frac{V}{Z} = \frac{220}{20\sqrt{2}} = \frac{11}{\sqrt{2}} \approx 7.8 \text{ A}$$

Phase angle:

$$\tan \phi = \frac{X}{R} = \frac{20}{20} = 1 \Rightarrow \phi = 45^\circ$$

Hence, the answer is option (3) 7.8A and 45° .

Q. 22 Which of the following options represent the variation of photoelectric current with property of light shown on the x -axis?

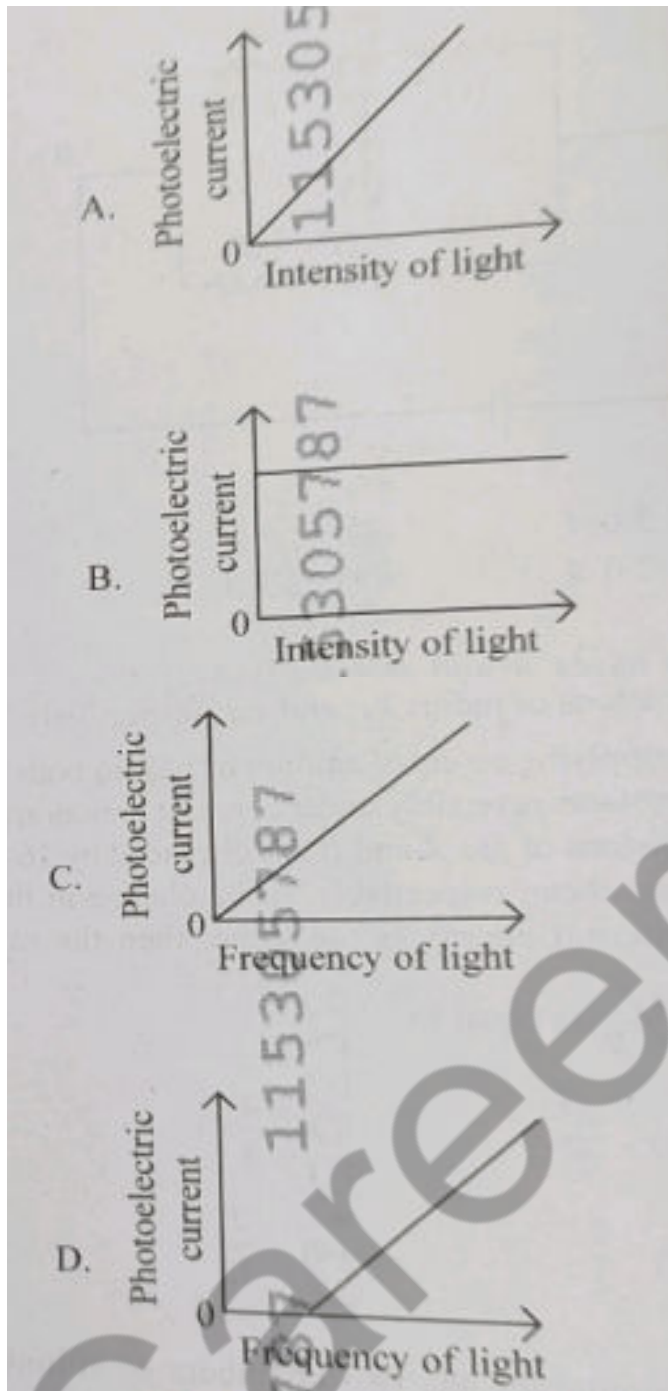

Option 1:
B and D

Option 2:
A only

Option 3:
A and C

Option 4:
A and D

Correct Answer:

A and D

Solution:

Correct Option: (4) A and D

Solution:

Photoelectric current increases linearly with the intensity of light when the frequency is above the threshold, as shown in graph A. Graph D correctly shows that below the threshold frequency, no current is emitted, and above it, the current becomes constant (assuming constant intensity).

Hence, the answer is option (4) A and D.

Q. 23 A pipe open at both ends has a fundamental frequency f in air. The pipe is now dipped vertically in a water drum to half of its length. The fundamental frequency of the air column is now equal to :

Option 1:

$$2f$$

Option 2:

$$\frac{f}{2}$$

Option 3:

$$f$$

Option 4:

$$\frac{3f}{2}$$

Correct Answer:

$$\frac{3f}{2}$$

Solution:

Correct Option: (4) $\frac{3f}{2}$

Solution:

Initially, the pipe is open at both ends, so it supports a fundamental frequency f with wavelength $\lambda = 2L$. When half is submerged, it behaves like a pipe open at one end (and closed at the other), now with effective length $L/2$. For such a pipe, the new fundamental frequency becomes $v/(4 \times L/2) = v/(2L)$, which is $3f/2$ when compared with the original.

Q. 24 Two identical point masses P and Q, suspended from two separate massless springs of spring constants k_1 and k_2 , respectively, oscillate vertically. If their maximum speeds are the same, the ratio (A_Q/A_P) of the amplitude A_Q of mass Q to the amplitude A_P of mass P is:

Option 1:

$$\sqrt{\frac{k_1}{k_2}}$$

Option 2:

$$\frac{k_2}{k_1}$$

Option 3:

$$\frac{k_1}{k_2}$$

Option 4:

$$\sqrt{\frac{k_2}{k_1}}$$

Correct Answer:

$$\sqrt{\frac{k_1}{k_2}}$$

Solution:

In SHM, maximum speed $v_{\max} = A\omega = A\sqrt{\frac{k}{m}}$

Given v_{\max} is same for both:

$$A_P\sqrt{k_1} = A_Q\sqrt{k_2} \Rightarrow \frac{A_Q}{A_P} = \sqrt{\frac{k_1}{k_2}}$$

Answer: (1) $\sqrt{\frac{k_1}{k_2}}$.

Q. 25 The output (Y) of the given logic implementation is similar to the output of an/a _____ gate.

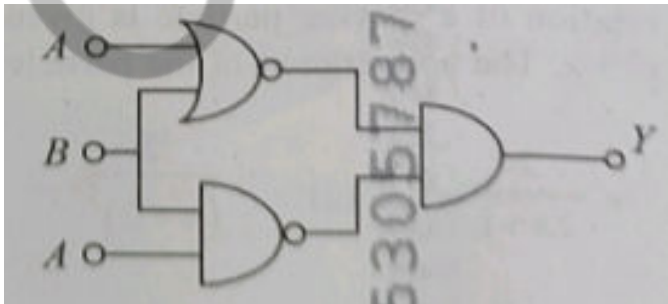

Option 1:

NOR

Option 2:

AND

Option 3:

NAND

Option 4:

OR

Correct Answer:

NAND

Solution:

Correct Option: (3) NAND

Solution:

Top gate: $A \text{ OR } B = A + B$

Bottom gate: $A \text{ OR } \bar{A} = A$

Final gate: AND of $(A + B)$ and $A = (A + B) \cdot A = A \cdot A + B \cdot A = A + AB = A$

But this passes through a NOT gate, so $Y = \bar{A}$, only when $B = 1$.

Truth table shows the behavior matches that of a NAND gate.

Hence, the answer is option (3) NAND.

Q. 26 An oxygen cylinder of volume 30 litre has 18.20 moles of oxygen. After some oxygen is withdrawn from the cylinder, its gauge pressure drops to 11 atmospheric pressure at temperature 27°C . The mass of the oxygen withdrawn from the cylinder is nearly equal to: [Given, $R = \frac{100}{12} \text{ J mol}^{-1} \text{ K}^{-1}$, and molecular mass of $\text{O}_2 = 32$, 1 atm pressure $= 1.01 \times 10^5 \text{ N/m}^2$]

Option 1:

0.144 kg

Option 2:

0.116 kg

Option 3:

0.156 kg

Option 4:

0.125 kg

Correct Answer:

0.156 kg

Solution:

Let x moles be removed.

From the question,

$$PV = (n - x)RT$$

$$11 \times 1.01 \times 10^5 \times \frac{30}{1000} = (18.20 - x) \times \frac{100}{12} \times 300$$

$$x = 4.868 \text{ mol}$$

$$\text{mass} = x \times \text{molecular mass} = 4.868 \times 32 \approx 0.156 \text{ kg}$$

Hence, the answer is the option 3.

Q. 27 In a certain camera, a combination of four similar thin convex lenses are arranged axially in contact. Then the power of the combination and the total magnification in comparison to the power (p) and magnification (m) for each lens will be, respectively -

Option 1:

$$p^4 \text{ and } m^4$$

Option 2:

$$4p \text{ and } 4m$$

Option 3:

$$p^4 \text{ and } 4m$$

Option 4:

$$4p \text{ and } m^4$$

Correct Answer:

$$4p \text{ and } m^4$$

Solution:

Power (P) of lenses in contact simply adds:

$$P_{\text{total}} = p + p + p + p = 4p$$

Magnification (m) of lenses in contact multiplies:

$$M_{\text{total}} = m \cdot m \cdot m \cdot m = m^4$$

Q. 28 Two gases A and B are filled at the same pressure in separate cylinders with movable pistons of radius r_A and r_B , respectively. On supplying an equal amount of heat to both the systems reversibly under constant pressure, the pistons of gas A and B are displaced by 16 cm and 9 cm, respectively. If the change in their internal energy is the same, then the ratio r_A/r_B is equal to

Option 1:

$$\frac{\sqrt{3}}{2}$$

Option 2:

$$\frac{4}{3}$$

Option 3:

$$\frac{3}{4}$$

Option 4:

$$\frac{2}{\sqrt{3}}$$

Correct Answer:

$$\frac{3}{4}$$

Solution:

Correct Option: (3) $\frac{3}{4}$

Solution:

Since heat supplied and internal energy change are the same for both gases, the work done by each gas must also be equal. Work at constant pressure is given by $P\Delta V$, and volume change is $\Delta V = \pi r^2 h$.

Using this, we get:

$$\pi r_A^2 \times 16 = \pi r_B^2 \times 9$$

Simplifying, $\frac{r_A^2}{r_B^2} = \frac{9}{16}$

Taking square root, $\frac{r_A}{r_B} = \frac{3}{4}$

Hence, the answer is option (3) $\frac{3}{4}$.

Q. 29 A balloon is made of a material of surface tension S and its inflation outlet (from where gas is filled in it) has small area A . It is filled with a gas of density ρ and takes a spherical shape of radius R . When the gas is allowed to flow freely out of it, its radius r changes from R to 0 (zero) in time T . If the speed $v(r)$ of gas coming out of the balloon depends on r as r^a and $T \propto S^\alpha A^\beta \rho^\gamma R^\delta$ then

Option 1:

$$a = \frac{1}{2}, \alpha = \frac{1}{2}, \beta = -\frac{1}{2}, \gamma = \frac{1}{2}, \delta = \frac{7}{2}$$

Option 2:

$$a = \frac{1}{2}, \alpha = \frac{1}{2}, \beta = -1, \gamma = +1, \delta = \frac{3}{2}$$

Option 3:

$$a = -\frac{1}{2}, \alpha = -\frac{1}{2}, \beta = -1, \gamma = -\frac{1}{2}, \delta = \frac{5}{2}$$

Option 4:

$$a = -\frac{1}{2}, \alpha = -\frac{1}{2}, \beta = -1, \gamma = \frac{1}{2}, \delta = \frac{7}{2}$$

Correct Answer:

$$a = -\frac{1}{2}, \alpha = -\frac{1}{2}, \beta = -1, \gamma = \frac{1}{2}, \delta = \frac{7}{2}$$

Solution:

Correct Option: (4)

Solution:

The pressure inside the balloon due to surface tension is $P \propto \frac{S}{r}$, which drives the gas out. Equating this pressure energy with kinetic energy gives $v \propto r^{-1/2}$, so $a = -\frac{1}{2}$.

The total time is $T \propto \frac{\text{mass}}{\text{rate}} \propto \frac{\rho R^3}{\rho A v} = \frac{R^3}{A v}$. Substituting $v \propto \sqrt{\frac{S}{\rho R}}$, we get:

$$T \propto \frac{R^3}{A} \cdot \sqrt{\frac{\rho R}{S}} = \frac{R^{7/2}}{A} \cdot \sqrt{\frac{\rho}{S}}$$

So the exponents are:

$$a = -\frac{1}{2}, \alpha = -\frac{1}{2}, \beta = -1, \gamma = \frac{1}{2}, \delta = \frac{7}{2}$$

Hence, the answer is option (4).

- Q. 30** A bob of heavy mass m is suspended by a light string of length l . The bob is given a horizontal velocity v_0 as shown in figure. If the string gets slack at some point P making an angle θ from the horizontal, the ratio of the speed v of the bob at point P to its initial speed v_0 is:

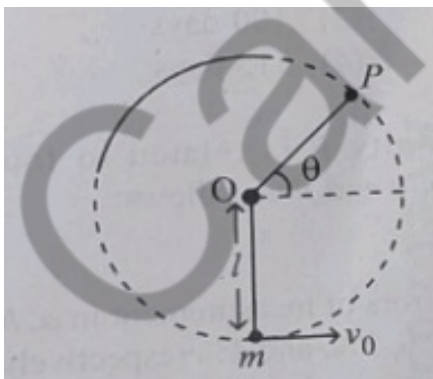

Option 1:

$$\left(\frac{\sin \theta}{2 + 3 \sin \theta} \right)^{1/2}$$

Option 2:

$$(\sin \theta)^{1/2}$$

Option 3:

$$\left(\frac{1}{2+3\sin\theta}\right)^{1/2}$$

Option 4:

$$\left(\frac{\cos\theta}{2+3\sin\theta}\right)^{1/2} \text{ solve in brief without headings}$$

Correct Answer:

$$\left(\frac{\cos\theta}{2+3\sin\theta}\right)^{1/2} \text{ solve in brief without headings}$$

Solution:

Using energy conservation:

$$v_0^2 = v^2 + 2gl(1 - \cos\theta)$$

From radial force condition at point P (when string just goes slack):

$$\frac{mv^2}{l} = mg \cos\theta \Rightarrow v^2 = gl \cos\theta$$

Substitute (2) into (1):

$$v_0^2 = gl \cos\theta + 2gl(1 - \cos\theta) = gl(2 + \cos\theta - 2\cos\theta) = gl(2 + 3\sin\theta)$$

So,

$$\frac{v^2}{v_0^2} = \frac{gl \cos\theta}{gl(2 + 3\sin\theta)} = \frac{\cos\theta}{2 + 3\sin\theta} \Rightarrow \frac{v}{v_0} = \left(\frac{\cos\theta}{2 + 3\sin\theta}\right)^{1/2}$$

Answer: Option (4).

Q. 31 A physical quantity P is related to four observations a , b , c and d as follows:

$$P = a^3 b^2 / c \sqrt{d}$$

The percentage errors of measurement in a , b , c and d are 1%, 3%, 2%, and 4% respectively. The percentage error in the quantity P is

Option 1:

15%

Option 2:

10%

Option 3:

2%

Option 4:

13%

Correct Answer:

10%

Solution:

The percentage error is,

$$\begin{aligned}\frac{\Delta P}{P} &= 3 \frac{\Delta a}{a} + 2 \frac{\Delta b}{b} + \frac{\Delta c}{c} + 0.5 \frac{\Delta d}{d} \\ \frac{\Delta P}{P} &= 3 \times 1\% + 2 \times 3\% + 1 \times 2\% + 0.5 \times 4\% \\ \frac{\Delta P}{P} &= 10\%\end{aligned}$$

Hence, the answer is the option 2.

Q. 32 The Sun rotates around its centre once in 27 days. What will be the period of revolution if the Sun were to expand to twice its present radius without any external influence? Assume the Sun to be a sphere of uniform density.

Option 1:

108 days

Option 2:

100 days

Option 3:

105 days

Option 4:

115 days

Correct Answer:

108 days

Solution:

If the sun were to expand, its angular momentum would remain constant.

We know,

$$L \propto \frac{I}{T} \propto \frac{R^2}{T}$$

Given, $R_2 = 2R_1$ and $T_1 = 27\text{days}$

$$\therefore \frac{R_1^2}{27\text{days}} = \frac{4R_1}{T_2}$$

$$T_2 = 4 \times 27 = 108\text{days}$$

Hence, the answer is the option 1.

Q. 33 The radius of Martian orbit around the Sun is about 4 times the radius of the orbit of Mercury. The Martian year is 687 Earth days. Then which of the following is the length of 1 year on Mercury ?

Option 1:

124 earth days

Option 2:

88 earth days

Option 3:

225 earth days

Option 4:

172 earth days

Correct Answer:

88 earth days

Solution:

Correct Option: (2) 88 earth days

Solution:

From Kepler's 3rd law, $T^2 \propto R^3$.

Let $T_M = 687$ days (Mars), $R_M = 4R$, and $T_{Me} = ?$

Using the ratio:

$$\left(\frac{T_M}{T_{Me}}\right)^2 = \left(\frac{R_M}{R_{Mc}}\right)^3 = 4^3 = 64$$

So,

$$\frac{T_M}{T_{Me}} = 8 \Rightarrow T_{Me} = \frac{T_M}{8} = \frac{687}{8} = 85.875 \approx 88 \text{ days}$$

Hence, the answer is option (2) 88 Earth days.

Q. 34 A wire of resistance R is cut into 8 equal pieces. From these pieces two equivalent resistances are made by adding four of these together in parallel. Then these two sets are added in series. The net effective resistance of the combination is

Option 1:

$$\frac{R}{8}$$

Option 2:

$$\frac{R}{64}$$

Option 3:

$$\frac{R}{32}$$

Option 4:

$$\frac{R}{16}$$

Correct Answer:

$$\frac{R}{16}$$

Solution:

Correct Option: (4) $\frac{R}{16}$

Solution:

1. The wire is cut into 8 equal pieces, so each piece has resistance:

$$R_{\text{piece}} = \frac{R}{8}$$

2. From these, form two groups of 4 resistors, each group has 4 pieces in parallel:

For one group:

$$\begin{aligned} \frac{1}{R_{\text{group}}} &= \frac{1}{R/8} + \frac{1}{R/8} + \frac{1}{R/8} + \frac{1}{R/8} = \frac{4}{R/8} = \frac{32}{R} \\ \Rightarrow R_{\text{group}} &= \frac{R}{32} \end{aligned}$$

3. Now, there are two such groups of resistance $R/32$, and they are connected in series:

$$R_{\text{net}} = \frac{R}{32} + \frac{R}{32} = \frac{2R}{32} = \frac{R}{16}$$

Q. 35 A photon and an electron (mass m) have the same energy E . The ratio ($\lambda_{\text{photon}} / \lambda_{\text{electron}}$) of their de Broglie wavelengths is: (c is the speed of light)

Option 1:

$$\frac{1}{c} \sqrt{h/2m}$$

Option 2:

$$\sqrt{E/2m}$$

Option 3:

$$c\sqrt{2mE}$$

Option 4:

$$c\sqrt{\frac{2m}{E}}$$

Correct Answer:

$$c\sqrt{\frac{2m}{E}}$$

Solution:

Photon's wavelength:

$$\lambda_{\text{photon}} = \frac{hc}{E}$$

Electron's de Broglie wavelength (using non-relativistic formula):

$$\lambda_{\text{electron}} = \frac{h}{p} = \frac{h}{\sqrt{2mE}}$$

Now take the ratio:

$$\frac{\lambda_{\text{photon}}}{\lambda_{\text{electron}}} = \frac{hc/E}{h/\sqrt{2mE}} = \frac{c}{E} \cdot \sqrt{2mE} = c \cdot \sqrt{\frac{2m}{E}}$$

- Q. 36** A sphere of radius R is cut from a larger solid sphere of radius $2R$ as shown in the figure. The ratio of the moment of inertia of the smaller sphere to that of the rest part of the sphere about the Y -axis is :

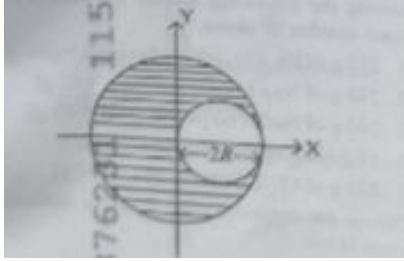

Option 1:

$$\frac{10}{104}$$

Option 2:

$$\frac{7}{8}$$

Option 3:

$$\frac{7}{40}$$

Option 4:

$$\frac{7}{57}$$

Correct Answer:

$$\frac{7}{57}$$

Solution:

- Big sphere radius = $2R$, so mass $\propto (2R)^3 = 8$ units
- Small sphere radius = R , so mass $\propto R^3 = 1$ unit
- Remaining mass = $8 - 1 = 7$ units

Now, moment of inertia of small sphere about Y -axis (using parallel axis theorem):

$$I_{\text{small}} = \frac{2}{5} \cdot 1 \cdot R^2 + 1 \cdot R^2 = \frac{7}{5} R^2$$

Moment of inertia of full sphere:

$$I_{\text{full}} = \frac{2}{5} \cdot 8 \cdot (2R)^2 = \frac{2}{5} \cdot 8 \cdot 4R^2 = \frac{64}{5} R^2$$

Remaining part:

$$I_{\text{rest}} = \frac{64}{5}R^2 - \frac{7}{5}R^2 = \frac{57}{5}R^2$$

Ratio:

$$\frac{I_{\text{small}}}{I_{\text{rest}}} = \frac{7}{57}$$

Q. 37 An electron (mass 9×10^{-31} kg and charge 1.6×10^{-19} C) moving with speed $c/100$ ($c =$ speed of light) is injected into a magnetic field \vec{B} of magnitude 9×10^{-4} T perpendicular to its direction of motion. We wish to apply an uniform electric field \vec{E} together with the magnetic field so that the electron does not deflect from its path. Then (speed of light $c = 3 \times 10^8$ ms $^{-1}$)

Option 1:

\vec{E} is parallel to \vec{B} and its magnitude is 27×10^4 V m $^{-1}$

Option 2:

\vec{E} is perpendicular to \vec{B} and its magnitude is 27×10^4 V m $^{-1}$

Option 3:

\vec{E} is perpendicular to \vec{B} and its magnitude is 27×10^2 V m $^{-1}$

Option 4:

\vec{E} is parallel to \vec{B} and its magnitude is 27×10^2 V m $^{-1}$

Correct Answer:

\vec{E} is perpendicular to \vec{B} and its magnitude is 27×10^4 V m $^{-1}$

Solution:

Correct Option: (2) \vec{E} is perpendicular to \vec{B} and its magnitude is 27×10^4 V m $^{-1}$

Solution:

For no deflection, the electric force must cancel the magnetic force:

$$qE = qvB \rightarrow E = vB$$

Given $v = c/100 = 3 \times 10^6$ m/s and $B = 9 \times 10^{-2}$ T,

$$E = (3 \times 10^6) \times (9 \times 10^{-2}) = 27 \times 10^4 \text{ V/m}$$

Electric field must be perpendicular to B and in opposite direction to magnetic force.

Q. 38 The electric field in a plane electromagnetic wave is given by

$$E_z = 60 \cos (5x + 1.5 \times 10^9 t) \text{ V/m}$$

Then expression for the corresponding magnetic field is (here, subscripts denote the direction of the field) :

Option 1:

$$B_y = 60 \sin (5x + 1.5 \times 10^9 t) T$$

Option 2:

$$B_y = 2 \times 10^{-7} \cos (5x + 1.5 \times 10^9 t) T$$

Option 3:

$$B_x = 2 \times 10^{-7} \cos (5x + 1.5 \times 10^9 t) T$$

Option 4:

$$B_z = 60 \cos (5x + 1.5 \times 10^9 t) T$$

Correct Answer:

$$B_y = 2 \times 10^{-7} \cos (5x + 1.5 \times 10^9 t) T$$

Solution:

Correct Option: (2)

$$B_y = 2 \times 10^{-7} \cos (5x + 1.5 \times 10^9 t) T$$

Solution:

In an electromagnetic wave, the electric and magnetic fields are perpendicular and the magnetic field amplitude is $B = E/c$. Given $E_0 = 60 \text{ V/m}$ and $c = 3 \times 10^8 \text{ m/s}$,

$$B_0 = 60 / (3 \times 10^8) = 2 \times 10^{-7} \text{ T.}$$

So the magnetic field has the same cosine form and is in the y -direction.

Q. 39 A body weighs 48 N on the surface of the earth. The gravitational force experienced by the body due to the earth at a height equal to one-third the radius of the earth from its surface is :

Option 1:

36 N

Option 2:

16 N

Option 3:

27 N

Option 4:

32 N

Correct Answer:

16 N

Solution:

The variation of g with height h is given as-

$$g' = g \left(1 - \frac{2h}{R} \right)$$
$$g' = g \left(1 - \frac{2R}{3R} \right)$$
$$g' = \frac{g}{3}$$

Thus the force will also be one-third.

$$F' = \frac{F}{3} = \frac{48}{3} = 16N$$

Hence, the answer is the option 2.

Q. 40 An unpolarized light beam travelling in air is incident on a medium of refractive index 1.73 at Brewster's angle. Then-

Option 1:

transmitted light is completely polarized with angle of refraction close to 30°

Option 2:

reflected light is completely polarized and the angle of reflection is close to 60°

Option 3:

reflected light is partially polarized and the angle of reflection is close to 30°

Option 4:

both reflected and transmitted light are perfectly polarized with angles of reflection and refraction close to 60° and 30° , respectively.

Correct Answer:

reflected light is completely polarized and the angle of reflection is close to 60°

Solution:

At Brewster's angle θ_B :

$$\tan \theta_B = n \Rightarrow \theta_B = \tan^{-1}(1.73) \approx 60^\circ$$

At this angle:

- Reflected light is completely polarized
- Angle of reflection = $\theta_B = 60^\circ$
- Angle of refraction = $90^\circ - \theta_B = 30^\circ$
- Transmitted light is partially polarized, not fully

Q. 41 A constant voltage of $50V$ is maintained between the points A and B of the circuit shown in the figure. The current through the branch CD of the circuit is :

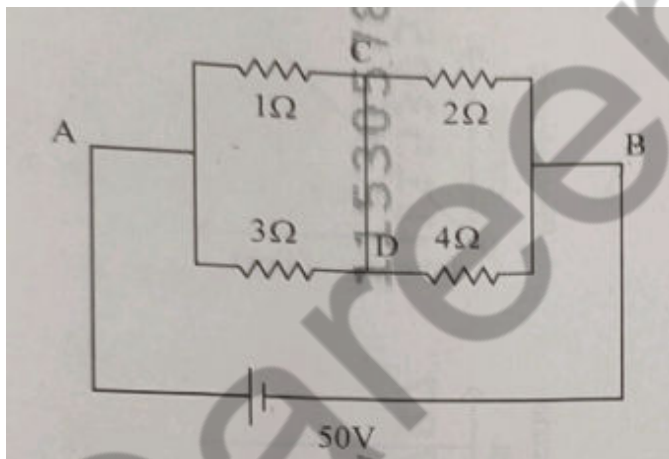

Option 1:

3.0 A

Option 2:

1.5 A

Option 3:

2.0 A

Option 4:

2.5 A

Correct Answer:

3.0 A

Q. 42 The plates of a parallel plate capacitor are separated by d . Two slabs of different dielectric constant K_1 and K_2 with thickness $\frac{3}{8}d$ and $\frac{d}{2}$, respectively are inserted in the capacitor. Due to this, the capacitance becomes two times larger than when there is nothing between the plates.

If $K_1 = 1.25K_2$, the value of K_1 is :

Option 1:

1.33

Option 2:

2.66

Option 3:

2.33

Option 4:

1.60

Correct Answer:

2.66

Solution:

Given dielectric thicknesses are $\frac{3}{8}d$, $\frac{1}{2}d$ and air gap $\frac{1}{8}d$. Using series formula:

$$\frac{1}{C} = \frac{3d}{8K_1\epsilon_0 A} + \frac{d}{2K_2\epsilon_0 A} + \frac{d}{8\epsilon_0 A} \Rightarrow \frac{1}{C} = \frac{d}{\epsilon_0 A} \left(\frac{3}{8K_1} + \frac{1}{2K_2} + \frac{1}{8} \right)$$

Given $C = 2C_0$, so:

$$\frac{3}{8K_1} + \frac{1}{2K_2} + \frac{1}{8} = \frac{1}{2}$$

Substitute $K_1 = 1.25K_2 \Rightarrow K_2 = \frac{K_1}{1.25}$, solve:

$$\frac{3}{K_1} + \frac{4 \cdot 1.25}{K_1} = 3 \Rightarrow \frac{8}{K_1} = 3 \Rightarrow K_1 = \frac{8}{3} \approx 2.66$$

Answer: (2) 2.66

Q. 43 Consider the diameter of a spherical object being measured with the help of a Vernier callipers. Suppose its 10 Vernier Scale Divisions (V.S.D.) are equal to its 9 Main Scale Divisions (M.S.D.). The least division in the M.S. is 0.1 cm and the zero of V.S. is at $x = 0.1$ cm when the jaws of Vernier callipers are closed.
If the main scale reading for the diameter is $M = 5$ cm and the number of coinciding vernier division is 8, the measured diameter after zero error correction, is

Option 1:
5.00 cm

Option 2:
5.18 cm

Option 3:
5.08 cm

Option 4:
4.98 cm

Correct Answer:
4.98 cm

Solution:

$$\text{Least Count (LC)} = 1\text{MSD} - 1\text{VSD}$$

$$= 0.1 - \frac{9}{10} \times 0.1 = 0.1 - 0.09 = 0.01 \text{ cm}$$

Zero Error = +0.1 cm \Rightarrow Subtract from final reading

Main Scale Reading (MSR) = 5.00 cm

Vernier Coinciding Division = 8 $\Rightarrow 8 \times 0.01 = 0.08$ cm

Total reading = 5.00 + 0.08 = 5.08 cm

Corrected reading = 5.08 - 0.10 = 4.98 cm

Q. 44 A 2 amp current is flowing through two different small circular copper coils having radii ratio 1 : 2. The ratio of their respective magnetic moments will be

Option 1:
4 : 1

Option 2:

1 : 4

Option 3:

1 : 2

Option 4:

2: 1^{-1}

Correct Answer:

1 : 4

Solution:

Given:

- Same current $I = 2 \text{ A}$ in both loops
- Radii ratio = 1:2

Then, area ratio $A_1 : A_2 = r_1^2 : r_2^2 = 1^2 : 2^2 = 1 : 4$

So, magnetic moment ratio:

$$M_1 : M_2 = IA_1 : IA_2 = A_1 : A_2 = 1 : 4$$

Q. 45 Consider a water tank shown in the figure. It has one wall at $x = L$ and can be taken to be very wide in the z direction. When filled with a liquid of surface tension S and density P , the liquid surface makes angle θ_0 ($\theta_0 \ll 1$) with the x -axis at $x = L$. If $y(x)$ is the height of the surface then the equation for $y(x)$ is

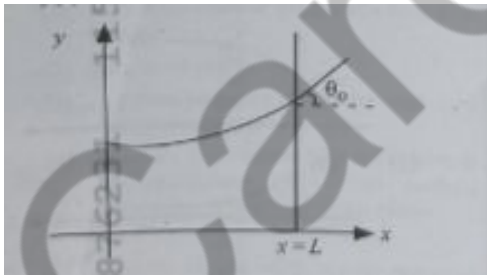

(take $\theta(x) = \sin \theta(x) = \tan \theta(x) = \frac{dy}{dx}$, g is the acceleration due to gravity)

Option 1:

$$\frac{dy}{dx} = \sqrt{\frac{\rho g}{S}} x$$

Option 2:

$$\frac{d^2y}{ds^2} = \frac{\rho g}{S} x$$

Option 3:

$$\frac{d^2y}{dx^2} = \frac{\rho g}{S} y$$

Option 4:

$$\frac{d^2y}{dx^2} = \sqrt{\frac{\rho g}{s}}$$

Correct Answer:

$$\frac{d^2y}{ds^2} = \frac{\rho g}{S} x$$

Solution:

The shape of the liquid surface is governed by a balance between:

- Pressure due to surface tension (related to the curvature, i.e., second derivative $\frac{d^2y}{dx^2}$)
- Hydrostatic pressure (due to gravity, $\rho g y(x)$)

The Young-Laplace equation for pressure difference due to curvature in a 2 D setup is:

$$P = S \cdot \frac{d^2y}{dx^2}$$

And the hydrostatic pressure at height y is:

$$P = \rho g y(x)$$

Equating the two:

$$S \cdot \frac{d^2y}{dx^2} = \rho g y(x) \Rightarrow \frac{d^2y}{dx^2} = \frac{\rho g}{S} y(x)$$

Chemistry

- Q. 1** Higher yield of NO in $\text{N}_2(\text{g}) + \text{O}_2(\text{g}) \rightleftharpoons 2\text{NO}(\text{g})$ can be obtained at [ΔH of the reaction = $+180.7 \text{ kJ mol}^{-1}$]
- A. higher temperature
 - B. lower temperature
 - C. higher concentration of N_2
 - D. higher concentration of O_2

Choose the correct answer from the options given below:-

Option 1:

A, C, D only

Option 2:

A, D only

Option 3:

B, C only

Option 4:

B, C, D only

Correct Answer:

A, C, D only

Solution:

A. Higher temperature

According to Le Chatelier's Principle, increasing temperature favors the endothermic direction (forward reaction here), so more NO is formed.

B. Lower temperature

This would favor the exothermic direction (reverse reaction), forming less NO.

C. Higher concentration of N_2

Adding more reactant shifts equilibrium forward, increasing NO yield.

D. Higher concentration of O_2

Same logic as above - more reactants push the reaction forward.

Hence, the correct answer is option (1).

Q. 2 Energy and radius of first Bohr orbit of He^+ and Li^{2+} are [Given $R_H = 2.18 \times 10^{-18} \text{ J}$, $a_0 = 52.9 \text{ pm}$]

Option 1:

$$\begin{aligned}E_n(\text{Li}^{2+}) &= -8.72 \times 10^{-16} \text{ J} \\r_n(\text{Li}^{2+}) &= 17.6 \text{ pm} \\E_n(\text{He}^+) &= -19.62 \times 10^{-16} \text{ J}; \\r_n(\text{He}^+) &= 17.6 \text{ pm}\end{aligned}$$

Option 2:

$$\begin{aligned}E_n(\text{Li}^{2+}) &= -12.62 \times 10^{-18} \text{ J}; \\r_n(\text{Li}^{2+}) &= 17.6 \text{ pm} \\E_n(\text{He}^+) &= -8.72 \times 10^{-18} \text{ J}; \\r_n(\text{He}^+) &= 26.4 \text{ pm}\end{aligned}$$

Option 3:

$$\begin{aligned}E_n(\text{Li}^{2+}) &= -8.72 \times 10^{-18} \text{ J} \\r_n(\text{Li}^{2+}) &= 26.4 \text{ pm} \\E_n(\text{He}^+) &= -19.62 \times 10^{-18} \text{ J}; \\r_n(\text{He}^+) &= 17.6 \text{ pm}\end{aligned}$$

Option 4:

$$\begin{aligned}E_n(\text{Li}^{2+}) &= -19.92 \times 10^{-16} \text{ J} \\r_n(\text{Li}^{2+}) &= 17.6 \text{ pm}^2 \\E_n(\text{He}^+) &= -8.72 \times 10^{-16} \text{ J}; \\r_n(\text{He}^+) &= 26.4 \text{ pm}\end{aligned}$$

Correct Answer:

$$\begin{aligned}E_n(\text{Li}^{2+}) &= -12.62 \times 10^{-18} \text{ J}; \\r_n(\text{Li}^{2+}) &= 17.6 \text{ pm} \\E_n(\text{He}^+) &= -8.72 \times 10^{-18} \text{ J}; \\r_n(\text{He}^+) &= 26.4 \text{ pm}\end{aligned}$$

Solution:

1. Energy of n^{th} orbit:

$$E_n = -R_H \cdot \frac{Z^2}{n^2}$$

2. Radius of n^{th} orbit:

$$r_n = a_0 \cdot \frac{n^2}{Z}$$

- For He^+ ($Z = 2, n = 1$):

$$- E = -2.18 \times 10^{-18} \cdot \frac{2^2}{1^2} = -8.72 \times 10^{-18} \text{ J}$$

$$- r = 52.9 \cdot \frac{1^2}{2^2} = 26.45 \text{ pm} \approx 26.4 \text{ pm}$$

- For Li^{2+} ($Z = 3, n = 1$):

$$- E = -2.18 \times 10^{-18} \cdot \frac{3^2}{1^2} = -19.62 \times 10^{-18} \text{ J}$$

$$- r = 52.9 \cdot \frac{1^2}{3} = 17.63 \text{ pm} \approx 17.6 \text{ pm}$$

So the correct values are:

$$- E_n (\text{He}^+) = -8.72 \times 10^{-18} \text{ J}, r = 26.4 \text{ pm}$$

$$- E_n (\text{Li}^{2+}) = -19.62 \times 10^{-18} \text{ J}, r = 17.6 \text{ pm}$$

Hence, the correct answer is option (2).

Q. 3

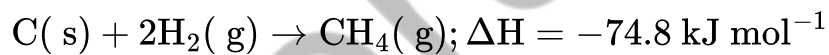

Which of the following diagrams gives an accurate representation of the above reaction?

[R \rightarrow reactants; P \rightarrow products]

Option 1:

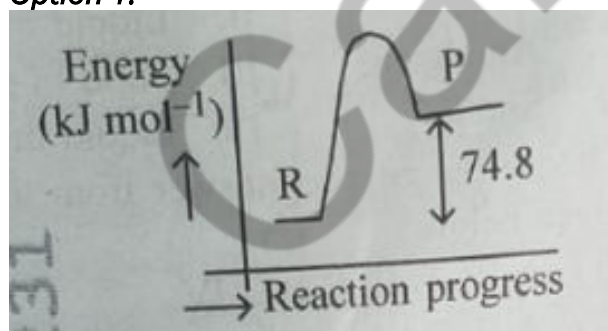

Option 2:

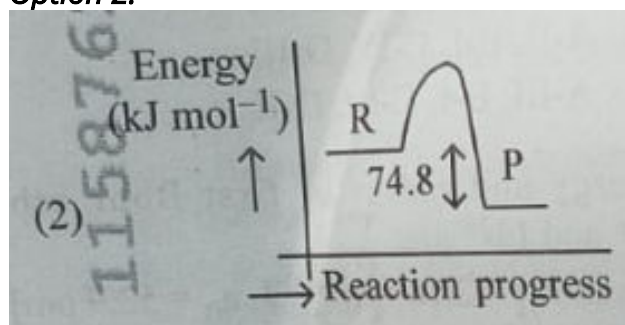

Option 3:

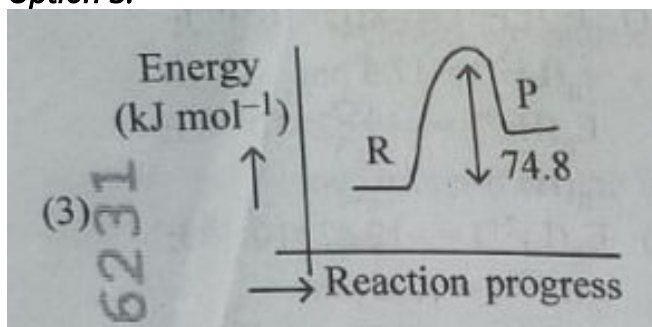

Option 4:

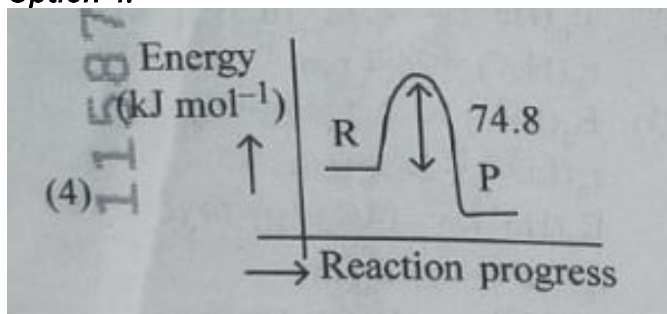

Correct Answer:

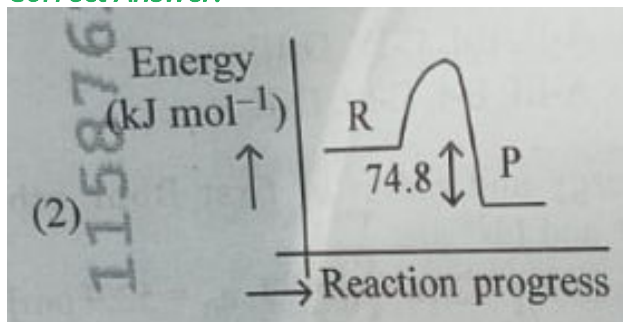

Solution:

Diagram 2:

- R is higher than P
- P is lower in energy
- The arrow from P to R is labeled 74.8 and points upward
- This is correct because it represents the energy difference, and $\Delta H = -74.8$ - the arrow shows that products are lower by 74.8 kJ/mol
- It's common to show the magnitude of ΔH with an upward arrow between P and R even in exothermic reactions, as long as positions are correct.

Hence, the correct answer is option (2).

Q. 4 Match List II with List - II

| List-I | List-II |
|-----------------------------------|--|
| A. XeO ₃ | I. sp ³ d; linear |
| B. XeF ₂ | II. sp ³ , pyramidal |
| C. XeOF ₄ ⁻ | III. sp ³ d ³ ; distorted octahedral |
| D. XeF ₆ | IV. sp ³ d ² ; square pyramidal |

Choose the correct answer from the options given below:

Option 1:

A-IV, B-II, C-I, D-III

Option 2:

A-II, B-L, C-IV, D-III

Option 3:

A-II, B-I, C-III, D-IV

Option 4:

A-IV, B-II, C-III, D-I

Correct Answer:

A-II, B-L, C-IV, D-III

Solution:

A. XeO₃

- Xenon has 8 valence electrons, forms **3Xe = O** double bonds and 1 lone pair
- Total regions = **3** bonds + 1 lone pair = **4** → sp³ hybridization
- Shape = Trigonal pyramidal

Match: II. sp³; pyramidal

B. XeF₂

- Xenon has 8 valence electrons, forms 2 bonds with **F**, and has 3 lone pairs
- Total regions = **2** bonds + 3 lone pairs = **5** → sp³d hybridization
- Electron geometry = trigonal bipyramidal; shape = linear (3 lone pairs occupy equatorial positions)

Match: I. sp³ d; linear

C. XeOF₄⁻

- Think of parent: XeOF₄ has 10, 4 F = 5 bonds + 1 lone pair = 6 regions → sp³ d²
- The anion (XeOF₄⁻) implies an extra electron, possibly altering geometry slightly, but overall still has 6 electron domains
- Likely shape = square pyramidal

Match: IV. sp^3 ; square pyramidal

D. XeF_6

- Xenon forms **6** bonds with F , and has 1 lone pair $\rightarrow 6 + 1 = 7$ regions

- Hybridization = sp^3d^3

- Geometry: distorted octahedral (due to lone pair)

Match: III. sp^3 ; distorted octahedral

Hence, the correct answer is option (2).

Q. 5 Identify the correct orders against the property mentioned

A. $H_2O > NH_3 > CHCl_3$ - dipole moment

B. $XeF_4 > XeO_3 > XeF_2$ - number of lone pairs on central atom

C. $O - H > C - H > N - O$ - bond length

D. $N_2 > O_2 > H_2$ - bond enthalpy

Choose the correct answer from the options given below :

Option 1:

B, C only

Option 2:

A, D only

Option 3:

B, D only

Option 4:

A, C only

Correct Answer:

A, D only

Solution:

$H_2O > NH_3 > CHCl_3$ - Dipole Moment

- Dipole moments (approximate):

- $H_2O \approx 1.85D$

- $NH_3 \approx 1.47D$

- $CHCl_3 \approx 1.01D$

The correct order, so A is correct.

$N_2 > O_2 > H_2$ - Bond enthalpy

Approximate bond enthalpies:

- $\text{N} \equiv \text{N} \approx 941 \text{ kJ/mol}$

- $\text{O} = \text{O} \approx 498 \text{ kJ/mol}$

- $\text{H} - \text{H} \approx 436 \text{ kJ/mol}$

The correct order, so D is correct

Hence, the correct answer is option (2).

Q. 6 Predict the major product 'P' in the following sequence of reactions -

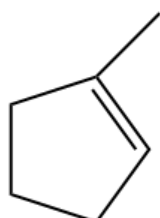

(i) HBr, benzoyl peroxide

(ii) KCN

(iii) Na(Hg)/C₂H₅OH

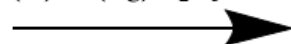

P
(Major)

Option 1:

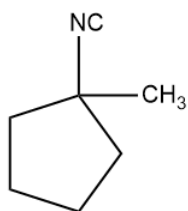

Option 2:

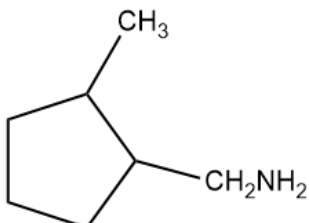

Option 3:

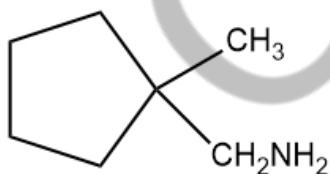

Option 4:

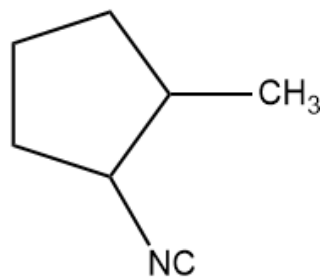

Correct Answer:

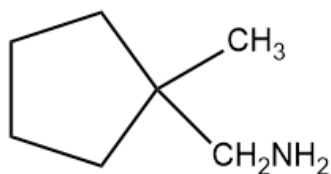

Solution:

Reagents and Steps:

(i) HBr , benzoyl peroxide

This indicates a free radical halogenation - an anti-Markovnikov addition of HBr .

So, Br adds to the less substituted carbon of the double bond:

Cyclopentylmethyl \rightarrow Cyclopentylmethyl bromide

(ii) KCN

This is a nucleophilic substitution:

Br is replaced by CN^- :

Cyclopentylmethyl bromide \rightarrow Cyclopentylmethyl cyanide

(iii) Na (Hg)/EtOH (Clemmensen reduction)

This reagent reduces $-\text{CN}$ to $-\text{CH}_2\text{NH}_2$:

Cyclopentylmethyl cyanide \rightarrow Cyclopentylmethylamine

Major Product (P):

Cyclopentane ring with $-\text{CH}_2\text{CH}_2\text{NH}_2$ as a side chain This matches Option (3).

Hence, the correct answer is option (3).

Q. 7 Which among the following electronic configurations belong to main group elements?

A. $[\text{Ne}]3s^1$

B. $[\text{Ar}]3d^34s^2$

C. $[\text{Kr}]4d^{16}5s^25p^4$

D. $[\text{Ar}]3d^{10}4s^1$

E. $[\text{Rn}]5f^06d^27s^2$

Choose the correct answer from the option given below :

Option 1:

A, C and D only

Option 2:

B and E only

Option 3:

A and C only

Option 4:

D and E only

Correct Answer:

A and C only

Solution:

A. $[\text{Ne}] 3s^1$

- This is s-block, Group 1 (like Na)

- ✓ Main group

B. $[\text{Ar}] 3d^3 4s^2$

- Has electrons in the d-orbital → d-block

- Likely a transition metal (e.g., Vanadium)

- ✗ Not main group

C. $[\text{Kr}] 4d^{10} 5s^2 5p^5$

- Valence shell: $5s^2 5p^5$

- Group 17 (Halogens)

- ✓ Main group

D. $[\text{Ar}] 3d^{10} 4s^1$

- Looks like Cu ($Z = 29$)

- Has filled d-orbitals → transition metal

- ✗ Not main group

E. $[\text{Rn}] 5f^0 6d^2 7s^2$

- Contains 6d electrons, possibly actinide or early d-block

- Example: Thorium ($Z = 90$)

- ✗ Not main group

Hence, the correct answer is option (3).

Q. 8 Match List - I with List - II

| List-I (Example) | List-II (Type of Solution) |
|------------------|----------------------------|
| A. Humidity | I. Solid in solid |
| B. Alloys | II. Liquid in gas |
| C. Amalgams | III. Solid in gas |
| D. Smoke | IV. Liquid in solid |

Choose the correct answer from the options given below:

Option 1:

A-III, B-II, C-I, D-IV

Option 2:

A-II, B-IV, C-I, D-III

Option 3:

A-II, B-I, C-IV, D-III

Option 4:

A-III, B-I, C-IV, D-II

Correct Answer:

A-II, B-I, C-IV, D-III

Solution:

A. Humidity

Humidity = water vapor in air

- Water is liquid, air is gas

Type: Liquid in gas → II

B. Alloys

Example: Brass (Zn in Cu), Steel (C in Fe)

- Metal solid dissolved in another solid

Type: Solid in solid → I

C. Amalgams

Metal + Mercury

- Mercury is a liquid, other metals are usually solid

Type: Liquid in solid → IV

D. Smoke

Solid particles (e.g., soot) in air

- Solid in gas

Type: Solid in gas → III

Hence, the correct answer is option (3).

Q. 9 Identify the suitable reagent for the following conversion.

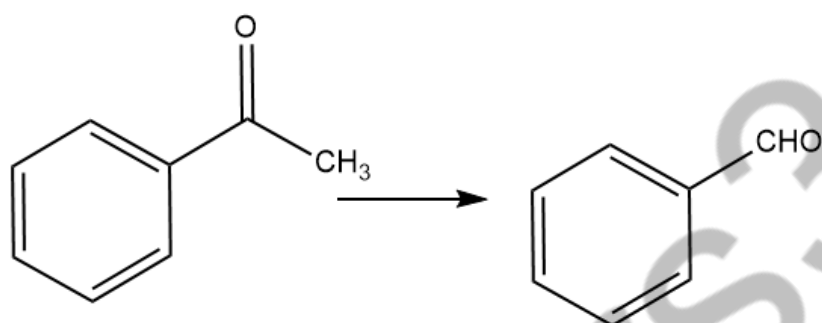

Option 1:

$\text{H}_2/\text{Pd} - \text{BaSO}_4$

Option 2:

(i) LiAlH_4 , (ii) $\text{H}^+/\text{H}_2\text{O}$

Option 3:

(i) $\text{AlH}(\text{iBu})_2$ (ii) H_2O

Option 4:

(i) NaBH_4 , (ii) $\text{H}^+/\text{H}_2\text{O}$

Correct Answer:

(i) $\text{AlH}(\text{iBu})_2$ (ii) H_2O

Solution:

DIBAL-H (Diisobutylaluminium hydride) at -78°C

It reduces esters to aldehydes selectively and does not reduce aldehydes further when used in cold conditions.

diisobutylaluminum hydride (DIBAL-H)



Hence, the correct answer is option (3).

Q. 10 The correct order of decreasing acidity of the following aliphatic acids is :

Option 1:



Option 2:

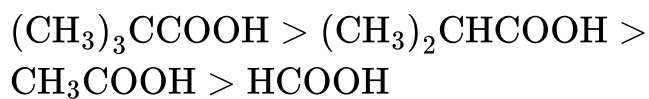

Option 3:

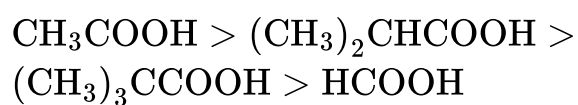

Option 4:

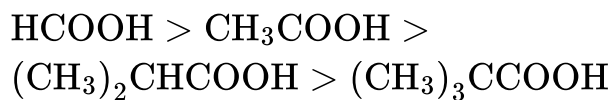

Correct Answer:

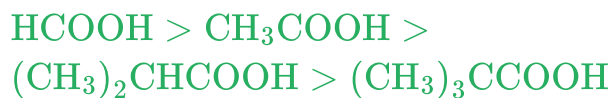

Q. 11 Which one of the following NOT belong to "Lassaigne's test"?

Option 1:

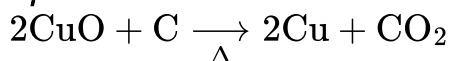

Option 2:

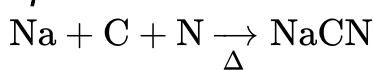

Option 3:

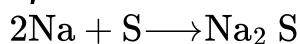

Option 4:

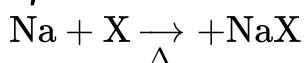

Correct Answer:



Solution:

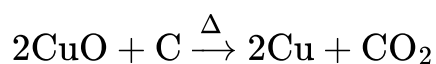

This reaction does not belong to the Lassaigne's test.

Explanation:

Lassaigne's test is a qualitative analysis used to detect nitrogen, sulfur, and halogens in an organic compound. It involves fusion with sodium (Na) to convert these elements into ionic, water-soluble forms that can be detected by specific tests.

Here's what the other options represent:

- (2): Formation of NaCN - used to detect nitrogen.

- (3): Formation of Na_2S - used to detect sulfur.

- (4): Formation of NaX - used to detect halogens ($\text{X} = \text{Cl}, \text{Br}, \text{I}$).

Option (1), involving CuO and C, is a reduction reaction, not part of Lassaigne's test.

It's unrelated to the sodium fusion method and is typically seen in inorganic reduction reactions or metallurgy.

Hence, the correct answer is option (1).

Q. 12 If the rate constant of a reaction is 0.03 s^{-1} . how much time does it take for 7.2 mol L^{-1} concentration of the reactant to get reduced to 0.9 mol L^{-1} ? (Given: $\log 2 = 0.3$)

Option 1:

21.0 s

Option 2:

69.3 s

Option 3:

23.1 s

Option 4:

210 s

Solution:

Given that

Initial concentration $[R]_0 = 7.2 \text{ mol/L}$

Final concentration $[R] = 0.9 \text{ mol/L}$

Rate constant $k = 0.03 \text{ s}^{-1}$

$\log 2 = 0.3$

Since units of k are s^{-1} , this is a first-order reaction.

$$\text{So, } t = \frac{2.303}{k} \log \left(\frac{[R]_0}{[R]} \right)$$

put value

$$t = \frac{2.303}{0.03} \log \left(\frac{7.2}{0.9} \right)$$

$$t = \frac{2.303}{0.03} \log(8)$$

Now,

$$\log(8) = \log(2^3) = 3 \log 2 = 3 \times 0.3 = 0.9$$

$$t = \frac{2.303}{0.03} \times 0.9 = 76.77 \times 0.9 = \mathbf{69.093s}$$

Hence the correct answer is (2)

Q. 13 Given below are two statements : Statement I : A hypothetical diatomic molecule with bond order zero is quite stable. Statement II : As bond order increases, the bond length increases. In the light of the above statements, choose the most appropriate answer from the options given below :

Option 1:

Statement 1 is false but Statement II is true

Option 2:

Both Statement I and Statement II are true

Option 3:

Both Statement I and Statement II are false

Option 4:

Statement 1 is true but Statement II is false

Solution:

A bond order of zero means no net bonding between the atoms, indicating the molecule cannot exist or is highly unstable. so the first statement is false

As bond order increases, bond length decreases because stronger bonding pulls the atoms closer together. and also the second statement is false

So the correct answer is (3) Both Statement I and Statement II are false

Q. 14 Out of the following complex compounds which of the compound will be having the minimum conductance in solution?

Option 1:

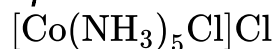

Option 2:

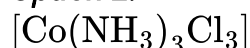

Option 3:



Option 4:

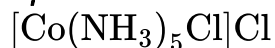

Solution:

Conductance depends on the number of ions a compound produces in solution.

1. $[\text{Co}(\text{NH}_3)_5\text{Cl}]\text{Cl} \rightarrow$ Dissociates as: $[\text{Co}(\text{NH}_3)_5\text{Cl}]^+ + \text{Cl}^- \rightarrow$ **2** ions
2. $[\text{Co}(\text{NH}_3)_3\text{Cl}_3] \rightarrow$ No counter ion outside, so it's a neutral complex \rightarrow **0** ions
3. $[\text{Co}(\text{NH}_3)_4\text{Cl}_2]\text{Cl} \rightarrow$ no Cl ion is outside the coordination sphere so it is also a neutral complex.
4. $[\text{Co}(\text{NH}_3)_6]^{3+}_{\text{Cl}} \rightarrow$ Dissociates as: $[\text{Co}(\text{NH}_3)_6]^{3+} + 3\text{Cl}^- \rightarrow$ **4** ions

So correct option is b and c .

Q. 15 Which of the following aqueous solution will exhibit highest boiling point?

Option 1:



Option 2:

0.01 M Urea

(3) 0.01M KNO_3

(4) 0.01M Na_2SO_4

Option 3:

0.01M KNO_3

Option 4:



Correct Answer:



Solution:

Boiling point elevation is a colligative property that depends on the amount of the substance. It depends on van't Hoff factor (i) \times concentration-

- Glucose (non-electrolyte): $i = 1$

- Urea (non-electrolyte): $i = 1$

- KNO_3 (strong electrolyte): $i = 2$ (1 K^+ and one nitrate ion)

- Na_2SO_4 (strong electrolyte): $i = 3$ (3 Na^+ ions and one sulphate ion)

Hence, the correct answer is option (4).

Q. 16 Given below are two statements : one is labelled as Assertion (A) and the other is labelled as Reason (R).

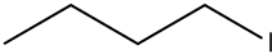
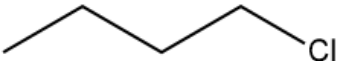
Assertion (A):  undergoes S_N2 reaction faster than 

Reason (**R**) : Iodine is a better leaving group because of its large size.

In the light of the above statements, choose the correct answer from the options given below :

Option 1:

A is false but **R** is true

Option 2:

Both **A** and **R** are true and **R** is the correct explanation of **A**

Option 3:

Both **A** and **R** are true but **R** is not the correct explanation of **A**

Option 4:

A is true but **R** is false

Correct Answer:

Both **A** and **R** are true and **R** is the correct explanation of **A**

Q. 17 Consider the following compounds :

$\text{K}\underline{\text{O}}_2$, $\text{H}_2\underline{\text{O}}_2$ and $\text{H}_2\underline{\text{S}}\text{O}_4$.

The oxidation states of the underlined elements in them are, respectively:

Option 1:

+4, -4, and +6

Option 2:

+1, -1, and +6

Option 3:

+2, -2, and +6

Option 4:

+1, -2, and +4

Correct Answer:

+4, -4, and +6

Solution:

• KO_2 (O in $\text{KO}_2 = -\frac{1}{2}$ (superoxide ion, O_2^-))

$$x + 2\left(-\frac{1}{2}\right) = 0 \Rightarrow x = 1$$

• H_2O_2 (O in $\text{H}_2\text{O}_2 = -1$ (peroxide))

$$2(+1) + 2x = 0 \Rightarrow 2 + 2x = 0 \Rightarrow x = -1$$

• H_2SO_4 (S in $\text{H}_2\text{SO}_4 = +6$)

$$2(+1) + x + 4(-2) = 0 \Rightarrow 2 + x - 8 = 0 \Rightarrow x = +6$$

Hence the correct option is (2)

Q. 18 Match List - I with List - II

List-I

- A. Haber process
- B. Wacker oxidation
- C. Wilkinson catalyst
- D. Ziegler catalyst

List-II

- I. Fe catalyst
- II. PdCl_2
- III. $[(\text{PPh}_3)_3\text{RhCl}]$
- IV TiCl_4 with $\text{coAl}(\text{CH}_3)_3$

Choose the correct answer from the options given below :

Option 1:

A-I, B-IV, C-III, D-II

Option 2:

A-I, B-II, C-IV, D-III

Option 3:

A-II, B-III, C-I, D-IV

Option 4:

A-I, B-II, C-III, D-IV

Correct Answer:

A-I, B-II, C-III, D-IV

Solution:

- A. Haber Process → Fe catalyst
- B. Wacker Oxidation → II. PdCl_2
- C. Wilkinson Catalyst →. $(\text{Ph}_3\text{P})_3\text{RhCl}$
- D. Ziegler Catalyst → IV. TiCl_4 with $\text{Al}(\text{CH}_3)_3$

Hence, the correct answer is option (4).

Q. 19 Given below are two statements :

Statement I : Like nitrogen that can form ammonia, arsenic can form arsine.

Statement II : Antimony cannot form antimony pentoxide.

In the light of the above statements, choose the most appropriate answer from the options given below:

Option 1:

Statement I is incorrect but Statement II is correct

Option 2:

Both Statement I and Statement II are correct

Option 3:

Both Statement I and Statement II are incorrect

Option 4:

Statement I is correct but Statement II is incorrect

Correct Answer:

Statement I is correct but Statement II is incorrect

Solution:

Yes, arsenic can also form arsine (AsH_3). It is an example of hydrides of group 15 elements.

Antimony can form antimony pentoxide (Sb_2O_5).

Hence, the correct answer is option (4).

Q. 20 Given below are two statements :

Statement I : Ferromagnetism is considered as an extreme form of paramagnetism.

Statement II : The number of unpaired electrons in a Cr^{2+} ion ($Z \subseteq 24$) is the same as that of a Nd^{3+} ion ($Z = 60$).

In the light of the above statements, choose the correct answer from the options given below :

Option 1:

Statement I is false but Statement II is true

Option 2:

Both Statement I and Statement II are true

Option 3:

Both Statement I and Statement II are false

Option 4:

Statement I is true but Statement II is false

Correct Answer:

Statement I is true but Statement II is false

Solution:

Ferromagnetism is considered an extreme form of paramagnetism. This is a true statement.

Cr^{2+} and Nd^{3+} have same unpaired electrons.

- Cr^{2+} : $[\text{Ar}]3d^4 \rightarrow 4$ unpaired electrons

- Nd^{3+} : $[\text{Xe}]4f^3 \rightarrow 3$ unpaired electrons

So they do not have the same number of unpaired electrons .

Hence, the correct answer is option (4).

Q. 21 Which one of the following reactions does, NOT give benzene as the product?

Option 1:

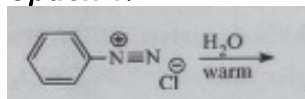

Option 2:

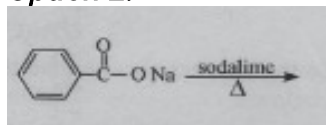

Option 3:

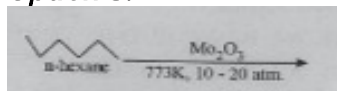

Option 4:

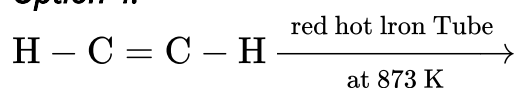

Solution:

1) BDC react with warm water Gives Phenol as product via loss of N_2 gas and replacement by H



3) n -Hexane + Mo_2O_3 at 773 K, 10 – 20 atm

→ This is aromatization, where n-hexane gets converted to benzene under high temperature and pressure with catalyst.

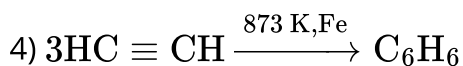

So the correct option is (1)

Q. 22 How many products (including stereoisomers) are expected from monochlorination of the following compound?

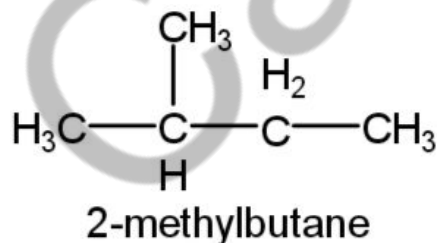

Option 1:

6

Option 2:

2

Option 3:

3

Option 4:

5

Correct Answer:

6

Solution:

Product I and III have one chiral centre, hence they give ($2^n = 2^1 = 2$) two optical isomers as products.

Total products = $2 + 1 + 2 + 1 = 6$

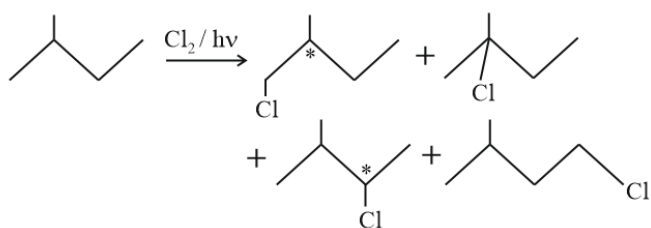

Hence, the correct answer is option (1).

Q. 23 Which of the following statements are true?

- A. Unlike Ga that has a very high melting point, Cs has a very low melting point.
 - B. On Pauling scale, the electronegativity values of N and Cl are not the same.
 - C. Ar , K^+ , Cl^- , Ca^{2+} , and S^{2-} are all isoelectronic species.
 - D. The correct order of the first ionization enthalpies of Na , Mg , Al , and Si is $\text{Si} > \text{Al} > \text{Mg} > \text{Na}$.
 - E. The atomic radius of Cs is greater than that of Li and Rb .
- Choose the correct answer from the options given below:

Option 1:

A, C and E only

Option 2:

A, B, and E only

Option 3:

C and E only

Option 4:

C and D only

Correct Answer:

C and E only

Solution:

Ga (Gallium) indeed has low high melting point too - so not true

Cs (Caesium) has a very low melting point (about 28.5°C)

In option C, all are isoelectronic ($\text{Ar} = 18e^{-}$, $\text{Cl}^{-} = 18e^{-}$, etc.).

Cs has a large atomic radius as atomic radius increases down the group.

Hence, the correct answer is option (3).

Q. 24 The standard heat of formation, in kcal/mol of Ba^{2+} is :
[Given : standard heat of formation of SO_4^{2-} ion (aq) = -216kcal/mol , standard heat of crystallisation of $\text{BaSO}_4(\text{s}) = -4.5\text{kcal/mol}$, standard heat of formation of $\text{BaSO}_4(\text{s})_5 = -349\text{kcal/mol}$]

Option 1:

+220.5

Option 2:

-128.5

Option 3:

-133.0

Option 4:

+133

Solution:

Given that

$$\Delta H_f^{\circ}(\text{BaSO}_4, \text{s}) = -349\text{kcal/mol}$$

$$\Delta H_f^{\circ}(\text{SO}_4^{2-}, \text{aq}) = -216\text{kcal/mol}$$

$$\Delta H_{\text{cryst}}^{\circ}(\text{BaSO}_4) = -4.5\text{kcal/mol}$$

Apply **Hess's Law**, consider the following reaction:

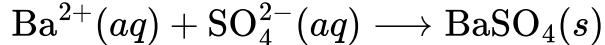

Enthalpy change for this reaction is the heat of crystallization:

$$\Delta H_{\text{rxn}} = \Delta H_{\text{cryst}} = -4.5 \text{ kcal/mol}$$

Using Hess's law:

$$\Delta H_f(\text{BaSO}_4) = \Delta H_f(\text{Ba}^{2+}) + \Delta H_f(\text{SO}_4^{2-}) + \Delta H_{\text{cryst}}$$

Rearranged to solve for $\Delta H_f(\text{Ba}^{2+})$:

$$\Delta H_f(\text{Ba}^{2+}) = \Delta H_f(\text{BaSO}_4) - \Delta H_f(\text{SO}_4^{2-}) - \Delta H_{\text{cryst}}$$

$$\Delta H_f(\text{Ba}^{2+}) = (-349) - (-216) - (-4.5)$$

$$\Delta H_f(\text{Ba}^{2+}) = -349 + 216 + 4.5$$

$$\Delta H_f(\text{Ba}^{2+}) = -128.5 \text{ kcal/mol}$$

Hence the correct option is (B)

- Q. 25** 78 Sugar 'X'
- A. is found in honey.
 - B. is a keto sugar.
 - C. exists in α and β -anomeric forms.
 - D. is levorotatory.
- 'X' is:
- (1) Sucrose
 - (2) D-Glucose
 - (3) D-Fructose
 - (4) Maltose

Option 1:
Sucrose

Option 2:
D-glucose

Option 3:
D-Fructose

Option 4:
Maltose

Correct Answer:
D-Fructose

Solution:

D-Fructose

- Found in honey

- It is a keto sugar (a ketose)

- γ Exists in α and β forms (furanose form has anomeric carbon)

- It is laevorotatory - even though it's D-fructose, it rotates light to the left

Hence, the correct answer is option (3).

Q. 26 Total number of possible isomers (both structural as well as stereoisomers) of cyclic ethers of molecular formula C_4H_8O is : (1) 11 (2) 6 (3) 8 (4) 10

Option 1:

11

Option 2:

6

Option 3:

8

Option 4:

10

Correct Answer:

6

Solution:

To find the total number of isomers (both structural and stereoisomers) of cyclic ethers with the molecular formula C_4H_8O , we can follow these steps:

Step 1: Determine the Degree of Unsaturation (DOU)

The formula for calculating the degree of unsaturation (DOU) is:

$$\text{DOU} = \frac{2C + 2 + N - H - X}{2}$$

Where:

- C = number of carbon atoms

- H = number of hydrogen atoms

- N = number of nitrogen atoms (not applicable here)

- X = number of halogens (not applicable here)

For C_4H_8O :

- $C = 4$

- $H = 8$

$$-N = 0$$

$$-X = 0$$

Substituting the values:

$$\text{DOU} = \frac{2(4) + 2 + 0 - 8 - 0}{2} = \frac{8 + 2 - 8}{2} = \frac{2}{2} = 1$$

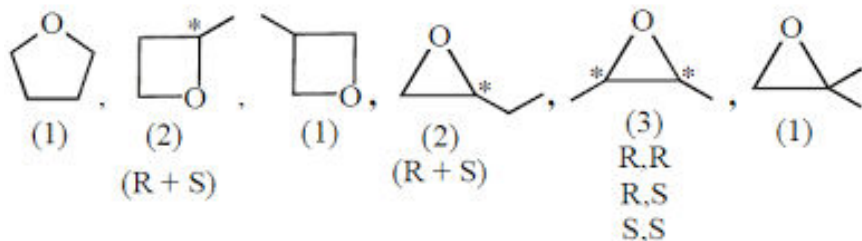

This indicates that there is one degree of unsaturation, which suggests the presence of one ring.

Step 2: Identify Possible Cyclic Structures

Given that we have one degree of unsaturation, we can form cyclic ethers. We will consider both 3-membered, 4-membered, and 5-membered rings.

3-Membered Ring (Epoxide)

- **Structure 1:** A 3-membered ring with one ethyl group (C_2H_5) and one oxygen atom.
- **Chirality:** This structure can have a chiral center, leading to one enantiomer.

4-Membered Ring (Butyrolactone)

- **Structure 2:** A 4-membered ring with one methyl group (CH_3) and one oxygen atom.
- **Chirality:** This structure can also have a chiral center, leading to one enantiomer.

5-Membered Ring (Tetrahydrofuran)

- **Structure 3:** A 5-membered ring with two methyl groups and one oxygen atom.
- **Chirality:** This structure does not have any chiral centers.

Step 3: Count the Isomers

1. 3-Membered Ring:

- 1 structure (chiral) + 1 enantiomer = 2 isomers

2. 4-Membered Ring:

- 1 structure (chiral) + 1 enantiomer = 2 isomers
- 1 achiral structure = 1 isomer
- Total = 2 + 1 = 3 isomers

3. 5-Membered Ring:

- 1 structure (achiral) = 1 isomer

Step 4: Total Isomers

Now, we sum all the isomers:

- From the 3-membered ring: 2
- From the 4-membered ring: 3
- From the 5-membered ring: 1

Total = 2 + 3 + 1 = **6 isomers**

Final Answer

The total number of isomers (considering both structural and stereoisomers) of cyclic ethers with the molecular formula C_4H_8O is **6**.

Hence, the correct answer is option (2).

Q. 27 For the reaction $A(g) \rightleftharpoons 2 B(g)$, the backward reaction rate constant is higher than the forward reaction rate constant by a factor of 2500, at 1000 K. [Given : $R = 0.0831 \text{ L atm mol}^{-1} (\text{K}^{-1})$] K_p for the reaction at 1000 K is

Option 1:

0.021

Option 2:

83.1

Option 3:

2.077×10^5

Option 4:

0.033

Correct Answer:

0.033

Solution:

We are given the reaction:

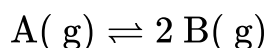

And told that:

- Rate constant of backward reaction is 2500 times the forward rate constant:

$$k_{\text{backward}} = 2500 \cdot k_{\text{forward}}$$

- Temperature $T = 1000 \text{ K}$

- Gas constant $R = 0.0831 \text{ L atm mol}^{-1} \text{ K}^{-1}$

We are asked to find K_p for the reaction.

Step 1: Use relationship between rate constants and equilibrium constant

For a reversible reaction, the equilibrium constant in terms of rate constants is:

$$K_c = \frac{k_{\text{forward}}}{k_{\text{backward}}} = \frac{1}{2500}$$

Step 2: Convert K_c to K_p

For gas-phase reactions, the relation is:

$$K_p = K_c(RT)^{\Delta n}$$

Here:

$$- \Delta n = 2 - 1 = 1$$

$$- R = 0.0831 \text{ L atm ctibu mol}^{-1} \text{ K}^{-1}$$

$$- T = 1000 \text{ K}$$

$$- K_c = \frac{1}{2500} = 0.0004$$

So:

$$K_p = 0.0004 \times (0.0831 \times 1000)^1 = 0.0004 \times 83.1 = 0.03324$$

Hence, the correct answer is option (4).

Q. 28 The ratio of the wavelengths of the light absorbed by a Hydrogen atom when it undergoes $n = 2 \rightarrow n = 3$ and $n = 4 \rightarrow n = 6$ transitions, respectively, is

Option 1:

$$\frac{1}{4}$$

Option 2:

$$\frac{1}{36}$$

Option 3:

$$\frac{1}{16}$$

Option 4:

$$\frac{1}{9}$$

Solution:

Given that,

Transition A: $n = 2 \rightarrow n = 3$

Transition B: $n = 4 \rightarrow n = 6$

We have

$$\Delta E \propto \left(\frac{1}{n_1^2} - \frac{1}{n_2^2} \right)$$

And since $\lambda \propto \frac{1}{\Delta E}$, we can write:

$$\frac{\lambda_1}{\lambda_2} = \frac{\Delta E_2}{\Delta E_1}$$

For $n = 2 \rightarrow 3$:

$$\Delta E_1 \propto \left(\frac{1}{2^2} - \frac{1}{3^2} \right) = \left(\frac{1}{4} - \frac{1}{9} \right) = \frac{5}{36}$$

For $n = 4 \rightarrow 6$:

$$\Delta E_2 \propto \left(\frac{1}{4^2} - \frac{1}{6^2} \right) = \left(\frac{1}{16} - \frac{1}{36} \right) = \frac{5}{144}$$

so the ratio is $\frac{\lambda_1}{\lambda_2} = \frac{\Delta E_2}{\Delta E_1} = \frac{\frac{5}{144}}{\frac{5}{36}} = \frac{1}{4}$

Hence the correct option is (1)

Q. 29 If the molar conductivity (Λ_m) of a $0,050 \text{ mol L}^{-1}$ solution of a monobasic weak acid is $90 \text{ S cm}^2 \text{ mol}^{-1}$, its extent (degree) of dissociation will be [Assume $A_+^{\circ} = 349.6 \text{ S cm}^2 \text{ mol}^{-1}$ and

$$A_-^{\text{E}} = 50.4 \text{ S cm}^2 \text{ mol}^{-1}]$$

Option 1:

0.215

Option 2:

0.115

Option 3:

0.125

Option 4:

0.225

Solution:

To calculate the degree of dissociation (α) of the weak monobasic acid, we use the formula:

$$\alpha = \frac{\Lambda_m}{\Lambda_m^\circ}$$

Given that

$$\Lambda_m = 90 \text{ S cm}^2 \text{ mol}^{-1}$$

$$\Lambda_m^\circ = A_+^\circ + A_-^\circ = 349.6 + 50.4 = 400 \text{ S cm}^2 \text{ mol}^{-1}$$

so put the value in

$$\alpha = \frac{\Lambda_m}{\Lambda_m^\circ}$$

$$\alpha = \frac{90}{400} = 0.225$$

Hence the correct option is (4)

Q. 30 5 moles of liquid X and 10 moles of liquid Y make a solution having a vapour pressure of 70 torr. The vapour pressures of pure X and Y are 63 torr and 78 torr respectively. Which of the following is true regarding the described solution?

Option 1:

The solution has volume greater than the sum of individual volumes.

Option 2:

The solution shows positive deviation.

Option 3:

The solution shows negative deviation.

Option 4:

The solution is ideal.

Correct Answer:

The solution shows negative deviation.

Solution:

We are given:

- Mole of $X = 5$
- Mole of $Y = 10$
- Total moles = 15

So:

- Mole fraction of X, $\chi_X = \frac{5}{15} = \frac{1}{3}$

- Mole fraction of Y, $\chi_Y = \frac{10}{15} = \frac{2}{3}$

Pure vapor pressures:

- $P_X^0 = 63$ torr

- $P_Y^0 = 78$ torr

Observed vapor pressure of the solution = 70 torr

Step 1: Calculate Expected Vapor Pressure (Ideal Solution)

Using Raoult's law for ideal solution:

$$P_{\text{deal}} = \chi_X P_X^0 + \chi_Y P_Y^0 = \left(\frac{1}{3}\right)(63) + \left(\frac{2}{3}\right)(78) = 21 + 52 = 73 \text{ torr}$$

Step 2: Compare with Given Vapor Pressure

- Expected (ideal): 73 torr

- Actual (given): 70 torr

- Actual < Ideal \Rightarrow Negative deviation

Hence, the correct answer is option (3).

Q. 31 Among the following. choose the ones with an equal number of atoms,

A. 212 g of Na_2CO_3 (s) [molar mass = 106 g]

B. 248 g of Na_2O (s) [molar mass = 62 g]

C. 240 g of NaOH (s) [molar mass = 40 g]

D. 12 g of H_2 (g) [molar mass = 2 g]

E. 220 g of CO_2 (g) [molar mass = 44 g]

Choose the correct answer from the options given below

Option 1:

B, D, and E only

Option 2:

A, B, and C only

Option 3:

A, B, and D only

Option 4:

B, C, and D only

Correct Answer:
A, B, and D only

Solution:

We need to calculate the total number of atoms in each option

so the formula

$$\text{Total atoms} = \text{Number of moles} \times (\text{Atoms per molecule}) \times N_A$$

A. 212 g of Na₂CO₃ (Molar mass = 106 g/mol)

• Moles = $212/106 = 2$

• Atoms per unit = 2 Na + 1 C + 3 O = **6 atoms**

• Total atoms = 2 × 6 = **12 atoms**

B. 248 g of Na₂O (Molar mass = 62 g/mol)

• Moles = $248/62 = 4$

• Atoms per unit = 2 Na + 1 O = **3 atoms**

• Total atoms = 4 × 3 = **12 atoms**

C. 240 g of NaOH (Molar mass = 40 g/mol)

• Moles = $240/40 = 6$

• Atoms per unit = 1 Na + 1 O + 1 H = **3 atoms**

• Total atoms = 6 × 3 = **18 atoms**

D. 12 g of H₂ (Molar mass = 2 g/mol)

• Moles = $12/2 = 6$

• Atoms per unit = 2 (H₂ molecule)

• Total atoms = 6 × 2 = **12 atoms**

E. 220 g of CO₂ (Molar mass = 44 g/mol)

• Moles = $220/44 = 5$

• Atoms per unit = 1 C + 2 O = **3 atoms**

• Total atoms = 5 × 3 = **15 atoms**

Hence the correct option is (3) A, B, and D only

Q. 32 Which of the following are paramagnetic?

Option 1:



Option 2:

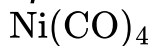

Option 3:



Option 4:

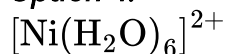

Solution:

| Complex | Oxidation State of Ni | Geometry | Ligand Type | Magnetic Nature |
|---|------------------------------|---------------|-------------------------------------|-----------------|
| A. $[\text{NiCl}_4]^{2-}$ | Ni^{2+} ($3d^8$) | Tetrahedral | Weak field (Cl^-) | Paramagnetic |
| B. $\text{Ni}(\text{CO})_4$ | Ni^0 ($3d^84s^2$) | Tetrahedral | Strong field (CO) | Diamagnetic |
| C. $[\text{Ni}(\text{CN})_4]^{2-}$ | Ni^{2+} ($3d^8$) | Square planar | Strong field (CN^-) | Diamagnetic |
| D. $[\text{Ni}(\text{H}_2\text{O})_6]^{2+}$ | Ni^{2+} ($3d^8$) | Octahedral | Weak field (H_2O) | Paramagnetic |
| E. $\text{Ni}(\text{PPh}_3)_4$ | Ni^0 ($3d^84s^2$) | Tetrahedral | Moderate field (PPh_3) | Paramagnetic |

Hence the correct option is (1)

Q. 33 If the half-life ($t_{1/2}$) for a first order reaction is 1 minute, then the time required for 99.9% completion of the reaction is closest to :

Option 1:

10 minutes

Option 2:

2 minutes

Option 3:

4 minutes

Option 4:

5 minutes

Correct Answer:

10 minutes

Solution:

For first order reaction-

$$t = \frac{6.9}{k} \text{ for } \sim 99.9\% \text{ completion (more accurately, } t = \frac{6.91}{k} \text{)}$$

Also half-life for a first order is given by-

$$t_{1/2} = \frac{0.693}{k} \Rightarrow k = \frac{0.693}{1} = 0.693 \Rightarrow t = \frac{6.91}{0.693} \approx 10 \text{ min}$$

Hence, the correct answer is option (1).

Q. 34 Among the given compounds I-III, the correct order of bond dissociation energy of the C-H bond marked with '*' is:

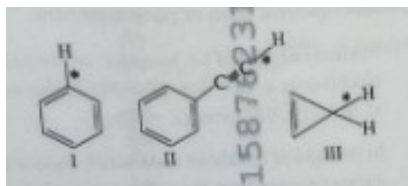

Option 1:

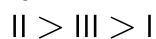

Option 2:

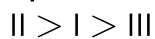

Option 3:

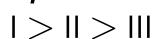

Option 4:

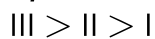

Solution:

Bond Dissociation Energy is the energy needed to break a bond. Lower BDE means the resulting radical is more stable.

So the Order of Stability (and hence inverse BDE) is Benzylic > Allylic > Methyl

Hence the correct answer is (3)

Q. 35 Dalton's Atomic theory could not explain which of the following?

Option 1:

Law of gaseous volume

Option 2:

Law of conservation of mass

Option 3:

Law of constant proportion

Option 4:

Law of multiple proportion

Correct Answer:

Law of gaseous volume

Solution:

Key Postulates of Dalton's Atomic Theory:

1. All matter is composed of atoms: Atoms are the fundamental, indivisible building blocks of all substances.
2. Atoms of a given element are identical: All atoms of the same element have the same properties, including mass and size.
3. Atoms of different elements differ: Atoms of different elements have different masses and properties.
4. Atoms combine in whole-number ratios: Atoms of different elements combine to form compounds in simple, whole-number ratios.
5. Atoms are neither created nor destroyed: In chemical reactions, atoms are rearranged, combined, or separated, but not created or destroyed.

Dalton's Atomic Theory does not explain Law of gaseous volume.

Hence, the correct answer is option (1).

Q. 36 Match List I with List II.

List I

(Name of
Vitamin)

- A. Vitamin B_{12}
- B. Vitamin D
- C. Vitamin B_2
- D. Vitamin B_6

List II

(Deficiency
disease)

- I. Cheilosis
- II. Convulsions
- III. Rickets
- IV. Pernicious anaemia

Choose the correct answer from the options given below :

Option 1:

A-IV, B-III, C-II, D-I

Option 2:

A-I, B-III, C-II, D-IV

Option 3:

A-IV, B-III, C-I, D-II

Option 4:

A-II, B-III, C-I, D-IV

Correct Answer:

A-IV, B-III, C-I, D-II

Solution:

Vitamin B_2 → Cheilosis

Vitamin B_{12} → Pernicious anaemia

Vitamin D → Rickets

Vitamin B_6 → Convulsions

Hence, the correct answer is option (3).

Q. 37 The correct order of decreasing basic strength of the given amines is :

Option 1:

benzenamine > ethanamine > N -methylaniline > N-ethylethanamine

Option 2:

N -methylaniline > benzenamine > ethanamine > N-ethylêthanamine

Option 3:

N-ethylethanamine > ethanamine > benzenamine > N-methylaniline

Option 4:

N -ethylethanamine > ethanamine > N -methylaniline > benzenamine

Correct Answer:

N-ethylethanamine > ethanamine > benzenamine > N-methylaniline

Solution:

Aliphatic amines are generally more basic than aromatic amines.

In aromatic amines like aniline and N-methylaniline, the lone pair on nitrogen is delocalized into the aromatic ring which reduces its availability for protonation.

Secondary aliphatic amines like N-ethylethanamine are more basic than primary ones like ethanamine due to the +I effect of the alkyl groups. The higher the +I, the higher will be the basicity.

Among aromatic amines, aniline is more basic than N-methylaniline because methyl substitution on nitrogen increases delocalization of the lone pair into the ring, making it less available for bonding with a proton.

Hence, the correct answer is option (3).

Q. 38 The correct order of the wavelength of light absorbed by the following complexes is,

- A. $[\text{Co}(\text{NH}_3)_6]^{3+}$
- B. $[\text{Co}(\text{CN})_6]^{3-}$
- C. $[\text{Cu}(\text{H}_2\text{O})_4]^{2+}$
- D. $[\text{Ti}(\text{H}_2\text{O})_6]^{3+}$

Choose the correct answer from the options given below:

Option 1:

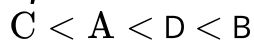

Option 2:

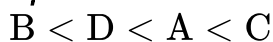

Option 3:



Option 4:

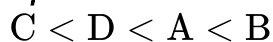

Solution:

Given Complexes:

A. $[\text{Co}(\text{NH}_3)_6]^{3+} \rightarrow \text{Co}^{3+}$, ligand = $\text{NH}_3 \rightarrow$ moderate field

B. $[\text{Co}(\text{CN})_6]^{3-} \rightarrow \text{Co}^{3+}$, ligand = $\text{CN}^- \rightarrow$ strong field (\rightarrow shortest λ absorbed)

C. $[\text{Cu}(\text{H}_2\text{O})_4]^{2+} \rightarrow \text{Cu}^{2+}$, ligand = $\text{H}_2\text{O} \rightarrow$ weak field

D. $[\text{Ti}(\text{H}_2\text{O})_6]^{3+} \rightarrow \text{Ti}^{3+}$, ligand = $\text{H}_2\text{O} \rightarrow$ weak field, but Ti^{3+} is $3d^1$, causes a d-d transition at moderate λ

So the order of crystal field strength is

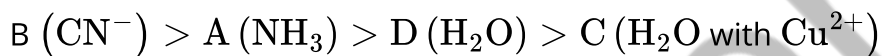

Hence, the correct answer is (4)

Q. 39 Which of the following does not decolorize bromine water?

Option 1:

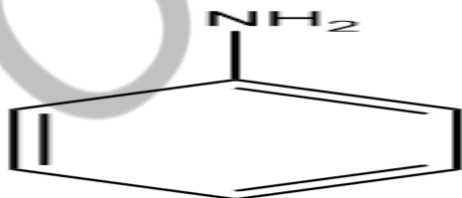

Option 2:

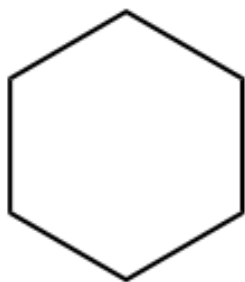

Option 3:

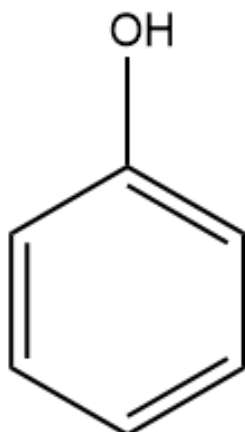

Option 4:

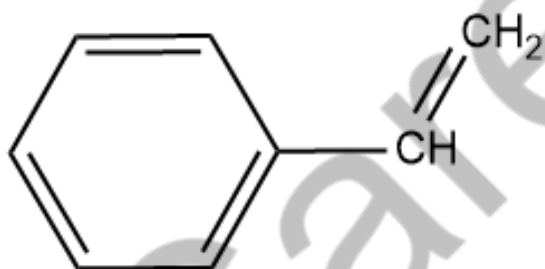

Correct Answer:

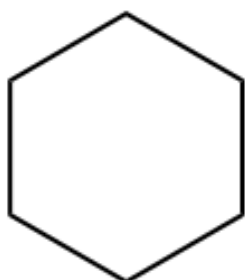

Solution:

Bromine water is decolorized by compounds with double bonds (like alkenes or activated benzene rings).

Aniline undergoes electrophilic substitution, not addition, and still decolorizes bromine water due to activation by $-\text{NH}_2$ group.

But among the given options, only cyclohexane will not decolorize the bromine water since it does not have double bonds .

Hence, the correct answer is option (2).

Q. 40 Match List I with List II

| List I (Mixture) | List II (Method of Separation) |
|--|--|
| A. $\text{CHCl}_3 + \text{C}_6\text{H}_5\text{NH}_2$ | I. Distillation under reduced pressure |
| B. Crude oil in petroleum industry | II. Steam distillation |
| C. Glycerol from spent-lye | III. Fractional distillation |
| D. Aniline + water | IV. Simple distillation |

Option 1:

A – II, B – IV, C – I, D – III

Option 2:

A – IV, B – III, C – II, D – I

Option 3:

A – IV, B – III, C – I, D – II

Option 4:

A – III, B – IV, C – I, D – II

Solution:

A. $\text{CHCl}_3 + \text{C}_6\text{H}_5\text{NH}_2$ (aniline)

• These are immiscible liquids, separated using steam distillation

→ Match: II

B. Crude oil in petroleum industry

• Crude oil is a complex mixture of hydrocarbons separated by fractional distillation

→ Match: III

C. Glycerol from spent lye (soap industry)

• Glycerol is separated using distillation under reduced pressure because it's temperature-sensitive

→ Match: I

D. Alcohol + Water (miscible liquids with different boiling points)

• These are separated by simple distillation

→ Match: IV

hence the correct option is (4) A – II, B – III, C – I, D – IV

Q. 41 Which one of the following compounds can exist as cis-trans isomers?

Option 1:

1,2-Dimethylcyclohexane

Option 2:

Pent-1-ene

Option 3:

2-Methylhex-2-ene

Option 4:

1,1-Dimethylcyclohexane

Solution:

1,2-Dimethylcyclohexane can exist as cis and trans forms due to restricted rotation in the cyclohexane ring.

Hence, the correct answer is (1)

Q. 42 Phosphoric acid ionizes in three steps with their ionization constant values K_{a_1} , K_{a_2} and K_{a_3} , respectively, while K is the overall ionization constant. Which of the following statements are true?

A. $\log K = \log K_{a_1} + \log K_{a_2} + \log K_{a_3}$

B. H_3PO_4 is a stronger acid than H_2PO_4^- and HPO_4^{2-} .

C. $K_{a_1} > K_{a_2} > K_{a_3}$

D. $K_{a_1} \times K_{a_2} \times K_{a_3} = \frac{K_{a_3} + K_{a_2}}{2}$

Choose the correct answer from the options given below:

Option 1:

A, B and C only

Option 2:

A and B only

Option 3:

A and C only

Option 4:

B, C and D only

Correct Answer:

A, B and C only

Solution:

H_3PO_4 is a stronger acid than H_2PO_4^- and HPO_4^{2-} due to successive loss of protons being more difficult.

$K = K_{a1} \times K_{a2} \times K_{a3} \Rightarrow \log K = \log K_{a1} + \log K_{a2} + \log K_{a3}$ - so this is also true

ionisation constant varies in the order $K_{a1} > K_{a2} > K_{a3}$

Hence, the correct answer is option (1).

Q. 43 Match List I with List II

List I

(Ion)

A. Co^{2+}

B. Mg^{2+}

C. Pb^{2+}

D. Al^{3+}

List II

(Group Number
in Cation Analysis)

I. Group-1

II. Group-III

III. Group-IV

IV. Group-VI

Choose the correct answer from the options given below :

Option 1:

A-III, B-II, C-I, D-IV

Option 2:

A-III, B-IV, C-II, D-I

Option 3:

A-III, B-IV, C-I, D-II

Option 4:

A-III, B-II, C-IV, D-I

Correct Answer:

A-III, B-IV, C-I, D-II

Solution:

| | | |
|-----------|--|---|
| Group I | Dil. HCl → forms Cl^- ppt | Pb^{2+} , Ag^+ , Hg_2^{2+} |
| Group II | H_2S in acidic medium | Cu^{2+} , Cd^{2+} , Bi^{3+} , Hg^{2+} |
| Group III | NH_4OH with NH_4Cl | Fe^{3+} , Al^{3+} , Cr^{3+} |
| Group IV | H_2S in basic medium | Zn^{2+} , Ni^{2+} , Co^{2+} , Mn^{2+} |
| Group V | $(\text{NH}_4)_2\text{CO}_3$ | Ba^{2+} , Sr^{2+} , Ca^{2+} |
| Group VI | No group ppt; Na^+ , K^+ , Mg^{2+} (flame tests etc.) | |

Hence, the correct answer is option (3).

Q. 44 Given below are two statements :

Statement 1 : Benzenediazonium salt is prepared by the reaction of aniline with nitrous acid at 273 – 278 K. It decomposes easily in the dry state.

Statement II: Insertion of iodine into the benzene ring is difficult, and hence iodobenzene is prepared through the reaction of benzenediazonium salt with KI.

In the light of the above statements, choose the most appropriate answer from the options given below :

Option 1:

Statement I is incorrect but Statement II is correct

Option 2:

Both Statement I and Statement II are correct

Option 3:

Both Statement 1 and Statement II are incorrect

Option 4:

Statement I is correct but Statement II is incorrect

Correct Answer:

Statement I is incorrect but Statement II is correct

Solution:

Insertion of iodine into the benzene ring is indeed difficult. So iodobenzene is prepared via a Sandmeyer-type reaction from diazonium salt using KI.

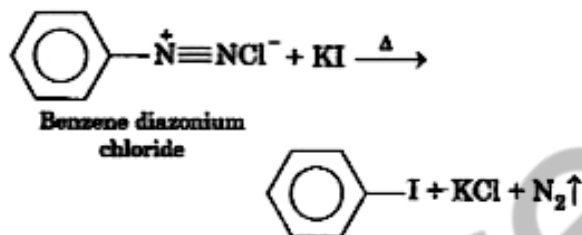

Benzenediazonium salt is prepared at 273–278 K. This temperature range (0–5°C) is used to stabilize the diazonium ion during its formation, as higher temperatures can lead to its decomposition. It does not decompose easily in the dry state.

Hence, the correct answer is option (1).

Q. 45 The major product of the following reaction is :

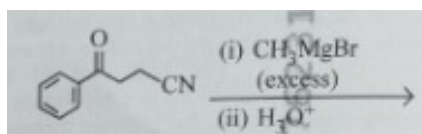

Option 1:

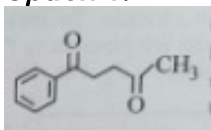

Option 2:

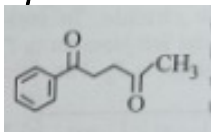

Option 3:

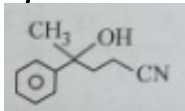

Option 4:

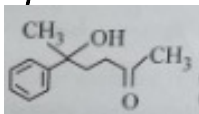

Solution:

We are given a compound with both a **ketone** and a **cyano (-CN)** group, and it is treated with **excess CH₃MgBr** (a Grignard reagent), followed by **acidic hydrolysis (H₃O⁺)**.

Grignard + Ketone → Tertiary alcohol

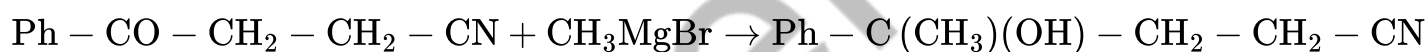

Grignard + Nitrile → Imine salt → on hydrolysis → Ketone



It shows **two tertiary alcohols** and **two CH₃ groups** on each alcohol carbon.

Hence the correct option is (4)

Biology

- Q. 1** In the above represented plasmid an alien piece of DNA is inserted at EcolI site. Which of the following strategies will be chosen to select the recombinant colonies!

Option 1:

Blue color colonies grown on ampicillin plates can be selected

Option 2:

Using ampicillin tetracycon containing medium plate

Option 3:

Blue color colongs will be selected.

Option 4:

White color collies will be selected

Correct Answer:

White color collies will be selected

Solution:

In plasmids like pUC19, the lacZ gene is used for blue-white screening. When foreign DNA is inserted into the lacZ region, the gene becomes disrupted, preventing the production of β -galactosidase. As a result, colonies with recombinant DNA appear white because X-gal cannot be cleaved, while non-recombinant colonies, which still have an intact lacZ gene, turn blue. Therefore, to select recombinant colonies, white color colonies should be chosen.

Hence, the correct answer is option 4.

Q. 2 The protein portion of an enzyme is called:

Option 1:

Prosthetic group

Option 2:

Cofactor

Option 3:

Coenzyme

Option 4:

Apoenzyme

Correct Answer:

Apoenzyme

Solution:

Apoenzyme is the protein portion of an enzyme that is inactive on its own.

It requires a non-protein component (cofactor or coenzyme) to become an active enzyme, called a holoenzyme.

Let's look at the other options:

- (1) Prosthetic group – A tightly bound, non-protein part of an enzyme (often organic) essential for activity.
- (2) Cofactor – A general term for non-protein helpers, can be metal ions or organic molecules.
- (3) Coenzyme – A loosely bound organic cofactor, often derived from vitamins.

Hence, the correct answer is option (4): Apoenzyme.

Q. 3 Given below are two statements:

Statement I: The primary source of energy in an ecosystem is solar energy.

Statement II: The rate of production of organic matter during photosynthesis in an ecosystem is called net primary productivity (NPP).

In the light of the above statements, choose the most appropriate answer from the options given below:

Option 1:

Statement I is incorrect but statement II is correct

Option 2:

Both statement I and statement II are correct

Option 3:

Both statement I and statement II are incorrect

Option 4:

Statement I is correct but statement II is incorrect

Correct Answer:

Both statement I and statement II are correct

Solution:

Solar energy is the ultimate source of energy for all ecosystems. It is captured by autotrophs (producers) through photosynthesis. Also, net primary productivity (NPP) is the rate at which producers store energy in the form of organic matter after using some for respiration. Thus, both statements are factually correct.

Hence, the correct answer is Option (2) Both statement I and statement II are correct

Q. 4 Given below are two statements: One is labelled as Assertion (A) and the other is labelled as Reason (R).

Assertion (A) : A typical unfertilised, angiosperm embryo sac at maturity is 8 nucleate and 7-celled.

Reason (R): The egg apparatus has 2 polar nuclei.

In the light of the above statements, choose the correct answer from the options given below:

Option 1:

A is false but R is true

Option 2:

Both A and R are true and R is the correct explanation of A.

Option 3:

Both A and R are true but R is NOT the correct explanation of A

Option 4:

A is true but R is false

Solution:

The angiosperm embryo sac at maturity has 8 nuclei and 7 cells — this is true.

But, the egg apparatus has 1 egg + 2 synergids, not polar nuclei.

The 2 polar nuclei are present in the central cell, not in the egg apparatus.

Hence, correct option is (4)

Q. 5 Neoplastic characteristics of cells refer to:

- A. A mass of proliferating cell
- B. Rapid growth of cells
- C. Invasion and damage to the surrounding tissue
- D. Those confined to original location

Choose the correct answer from the options given below:

Option 1:
B, C, D only

Option 2:
A, B only

Option 3:
A, B, C only

Option 4:
A, B, D only

Solution:

Explanation:

- **A. A mass of proliferating cells** – Neoplasia refers to abnormal mass of tissue due to excessive proliferation.
- **B. Rapid growth of cells** – Uncontrolled and rapid cell division is a hallmark of neoplasia.
- **C. Invasion and damage to surrounding tissue** – Especially in **malignant neoplasms**, which invade nearby tissues.
- **D. Those confined to original location** – This refers to **benign tumors**, not a general feature of all neoplastic cells.

Hence, the correct answer is: Option 3 – A, B, C only.

Q. 6 Which one of the following is the characteristic feature of gymnosperms?

Option 1:
Gymnosperms have flowers for reproduction.

Option 2:
Seeds are enclosed in fruits.

Option 3:
Seeds are naked.

Option 4:

Seeds are absent.

Correct Answer:

Seeds are naked.

Solution:

Gymnosperms are seed-producing plants but **do not form fruits**. Their seeds are **naked**, meaning they are **not enclosed within a fruit**, unlike angiosperms. They also **lack flowers** and reproduce using **cones**. Hence, the defining feature of gymnosperms is the presence of **naked seeds**.

Correct Answer: (3) Seeds are naked.

Q. 7 Match List - I with List - II

List - I

I. Pars intermedia

II. Ovary

III. Adrenal medulla
hormone

IV. Corpus luteum

List - II

A. Progesterone

B. Relaxin

C. Melanocyte-stimulating

D. Catecholamines

Option 1:

A-III, B-II, C-IV, D-I

Option 2:

A-IV, B-II, C-I, D-III

Option 3:

A-IV, B-II, C-III, D-I

Option 4:

A-II, B-IV, C-I, D-III

Solution:

A. Progesterone:

Progesterone is a hormone produced by the Corpus luteum (IV) in females after ovulation. It helps in maintaining the uterine lining for pregnancy.

B. Relaxin:

Relaxin is a hormone produced by the Ovary (II) during pregnancy. It helps in relaxing the pelvic ligaments and softening the cervix in preparation for childbirth.

C. Melanocyte-stimulating hormone (MSH):

MSH is produced by the Pars intermedia (I) of the pituitary gland. It regulates the production of melanin, affecting skin pigmentation.

D. Catecholamines:

Catecholamines (including adrenaline and noradrenaline) are produced by the Adrenal medulla (III) and are involved in the body's response to stress, increasing heart rate and blood pressure.

Hence, the correct matching is option (2): A-IV, B-II, C-I, D-III.

Q. 8 Which chromosome in the human genome has the highest number of genes?

Option 1: Chromosome 10

Option 2: Chromosome X

Option 3: Chromosome YYY

Option 4: Chromosome 1

Option 1:

Chromosome 10

Option 2:

Chromosome X

Option 3:

Chromosome YYY

Option 4:

Chromosome 1

Correct Answer:

Chromosome 1

Solution:

According to the Human Genome Project (HGP), **Chromosome 1** is the **largest human chromosome** and contains the **highest number of genes**, with over **2,000 functional genes**.

In contrast, **Chromosome Y** has the fewest genes (about 50–200), and **Chromosome X** has fewer than Chromosome 1.

Hence, the correct answer is option 4) Chromosome 1

Q. 9 Which of the following statements about RuBisCO is true?

Option 1:

It catalyzes the carboxylation of RuBP.

Option 2:

It is active only in the dark.

Option 3:

It has higher affinity for oxygen than carbon dioxide.

Option 4:

It is an enzyme involved in the photolysis of water.

Correct Answer:

It catalyzes the carboxylation of RuBP.

Solution:

Option (1) is correct:

RuBisCO (Ribulose biphosphate carboxylase/oxygenase) is the key enzyme involved in the calvin cycle (dark reaction) of photosynthesis. It catalyzes the carboxylation of ribulose biphosphate (RuBP), fixing carbon dioxide (CO_2) to RuBP and forming two molecules of 3-phosphoglycerate (3-PGA). This is the first step in carbon fixation during photosynthesis.

Option (2) is incorrect:

RuBisCO is not only active in the dark. It is involved in the Calvin cycle, which occurs in the stroma of chloroplasts and is independent of light, though it indirectly depends on the products of light reactions (ATP and NADPH).

Option (3) is incorrect:

RuBisCO has a higher affinity for carbon dioxide (CO_2) than for oxygen (O_2). However, it can also bind to oxygen, leading to photorespiration, but its affinity for CO_2 is greater under normal conditions.

Option (4) is incorrect:

RuBisCO is not involved in the photolysis of water. The photolysis of water is carried out by another enzyme, water-splitting complex (part of Photosystem II), which helps release oxygen in the light-dependent reactions.

Hence, the correct answer is option (1): It catalyzes the carboxylation of RuBP.

Q. 10 ----'

The first menstruation is called :

Option 1:

Ovulation

Option 2:
Menopause

Option 3:

Menarche

Option 4:

Diapause

Solution:

Menarche refers to the first menstruation of a girl, symbolizing the beginning of her reproductive age. It typically takes place between 10 and 16 years of age, depending on such factors as heredity, diet, and general health. This marks the initiation of the menstrual cycle, in which the uterine lining periodically bleeds if conception fails to take place.

Hence, the Correct Option is (3) Menarche

Q. 11 Which of the following genetically engineered organisms was used by Eli Lilly to prepare human insulin?

Option 1:
Phage

Option 2:
Bacterium

Option 3:
Yeast

Option 4:
Virus

Correct Answer:
Bacterium

Solution:

Eli Lilly, an American company, prepared the first genetically engineered human insulin using **recombinant DNA technology**. In this method, **two DNA sequences** corresponding to the A and B chains of human insulin were inserted into **bacteria (E. coli)**. These bacteria then produced the insulin chains, which were later purified and chemically joined to form active insulin.

Hence, the correct answer is Option (2).

Q. 12

Given below are two statements : one is labelled as Assertion (A) and the other is labelled as Reason ®.1

Assertion (A) : All vertebrates are chordates but all chordates are not vertebrate.

Reason (R) : The members of subphylum vertebrata possess notochord during the embryonic period, the notochord is replaced by a cartilaginous or bony vertebral column in adults.

In the light of the above statements, choose the correct answer from the options given below:

Option 1:

(1) A is false but R is true

Option 2:

Both A and R are true and A is the correct explanation of R

Option 3:

Both A and R are true but A is not the correct explanation of R

Option 4:

A is true but R is false

Solution:

The Assertion (A) is true as all vertebrates are members of the phylum Chordata (they constitute a subphylum of chordates), but all chordates are not vertebrates. Certain chordates, such as urochordates (e.g., tunicates) and cephalochordates (e.g., Amphioxus),

fail to develop a vertebral column.

The Reason (R) is also correct. In vertebrates, there is a notochord during embryonic development, which subsequently gets replaced by a vertebral column (backbone) formed of cartilage or bone in adults.

As the replacement of notochord by vertebral column is a characteristic feature distinguishing vertebrates from other chordates, R is able to explain A correctly.

Hence, the right answer is option (2) Both A and R are true and R is the correct explanation of A.

Q. 13 What is the main function of the spindle fibers during mitosis?

Option 1:

To regulate cell growth

Option 2:

To separate the chromosomes

Option 3:

To synthesize new DNA

Option 4:

To repair damaged DNA

Solution:

During mitosis, spindle fibers are responsible for attaching to the centromeres of chromosomes and pulling the sister chromatids apart to opposite poles of the cell. This ensures that each daughter cell receives an equal and accurate set of chromosomes.

Hence, the correct answer is Option (2).

Q. 14 Match **List I** with **List II**:

List I

- A. Alfred Hershey and Martha Chase
- B. Euchromatin
- C. Frederick Griffith
- D. Heterochromatin

List II

- I. Streptococcus pneumoniae
- II. Densely packed and dark-stained
- III. Loosely packed and light-stained
- IV. DNA as genetic material confirmation

Option 1:

A-III, B-II, C-IV, D-I

Option 2:

A-II, B-IV, C-I, D-III

Option 3:

A-IV, B-II, C-I, D-III

Option 4:

A-IV, B-III, C-I, D-II

Correct Answer:

A-IV, B-III, C-I, D-II

Solution:

- A. Alfred Hershey and Martha Chase → IV. DNA as genetic material confirmation
(Used bacteriophage experiments to prove DNA is the genetic material)
- B. Euchromatin → III. Loosely packed and light-stained
(Transcriptionally active part of chromatin)
- C. Frederick Griffith → I. Streptococcus pneumoniae
(Discovered transformation using this bacterium)
- D. Heterochromatin → II. Densely packed and dark-stained
(Transcriptionally inactive chromatin)

Q. 15 Match List I with List II.

List I

A. Adenosine

B. Adenylic acid

C. Adenine

D. Alanine

List II

I. Nitrogen

II. Nucleotide

III. Nucleoside

IV. Amino acid

Option 1:

A-II, B-III, C-I, D-IV

Option 2:

A-III, B-IV, C-II, D-I

Option 3:

A-III, B-II, C-IV, D-I

Option 4:

A-II, B-II, C-I, D-IV

Solution:

A. Adenosine → III. Nucleoside

Adenosine is a nucleoside, composed of the nitrogenous base adenine and a sugar (ribose).

B. Adenylic acid → II. Nucleotide

Adenylic acid (or AMP, adenosine monophosphate) is a nucleotide, consisting of a nucleoside (adenosine) and a phosphate group.

C. Adenine → I. Nitrogen

Adenine is a nitrogenous base, and nitrogen is a key component of its structure.

D. Alanine → IV. Amino acid

Alanine is an amino acid, a basic building block of proteins.

Hence, option(3) is correct.

Q. 16 In frog, the Renal portal system is a special venous connection that acts to link:

Option 1:

Kidney and lower part of body

Option 2:

Liver and intestine

Option 3:

Liver and kidney

Option 4:

Kidney and intestine

Correct Answer:

Liver and kidney

Solution:

In frogs, the renal portal system is a unique system that collects blood from the hindlimbs and other posterior parts of the body and directs it into the kidneys before returning it to the heart. The system primarily connects the liver and kidney, allowing partial filtration of blood in the kidneys before entering circulation again.

- Q. 17** Which of the following are the posttranscriptional events in an eukaryotic cell?
- A. Transport of pre-mRNA to cytoplasm prior to splicing.
 - B. Removal of introns and joining of exons.
 - C. Addition of methyl group at 5'5' end of hnRNA.
 - D. Addition of adenine residues at 3' end of hnRNA.
 - E. Base pairing of two complementary RNAs.

Option 1:

C, D, E only

Option 2:

A, B, C only

Option 3:

B, C, D only

Option 4:

B, C, E only

Correct Answer:

B, C, D only

Solution:

In eukaryotic cells, the initial RNA transcript (hnRNA) undergoes several posttranscriptional modifications before becoming functional mRNA. These include:

- Removal of introns and joining of exons (splicing) (B)
- Addition of a methylated cap at the 5'5' end (C)
- Addition of a poly-A tail (adenine residues) at the 3'3' end (D)

Statement A is incorrect because splicing occurs in the nucleus before the RNA is transported to the cytoplasm.

Statement E is unrelated to typical mRNA processing — it refers to RNA-RNA interactions like in RNA interference.

Hence, the correct answer is option 3) B, C, D only

-
- Q. 18** Polymerase chain reaction (PCR) amplifies DNA following the equation

Option 1:

$2N^2$

Option 2:
 N^2

Option 3:
 2^n

Option 4:
 $2n + 1$

Correct Answer:
 2^n

Solution:

The polymerase chain reaction (PCR) is used to amplify DNA. After each cycle of PCR, the amount of DNA doubles. So, if there are n cycles, the DNA is amplified by a factor of 2^n .

Hence, the correct answer is Option (3).

Q. 19 . Match List I with List II

List I:

A. Emphysema

List II:

I. Rapid spasms in muscle due to low Ca^{2+} in body fluid

II. Damaged alveolar walls and decreased respiratory surface

III. Acute chest pain when not enough oxygen is reaching to heart muscles

IV. Inflammation of glomeruli of kidney

B. Angina Pectoris

C. Glomerulo-nephritis

D. Tetany

Option 1:
A-II, B-III, C-IV, D-I

Option 2:

A-II, B-I, C-IV, D-III

Option 3:

A-I, B-II, C-I, D-IV

Option 4:

A-II, B-IV, C-III, D-I

Correct Answer:

A-II, B-III, C-IV, D-I

Solution:

Explanation (NEET Style):

Let's match each term from List I with its correct description from List II:

A. Emphysema → II.

Caused by damage to alveolar walls, resulting in decreased respiratory surface for gas exchange.

B. Angina Pectoris → III.

An acute chest pain due to insufficient oxygen supply to heart muscles, often during exertion.

C. Glomerulonephritis → IV.

An inflammation of the glomeruli in the kidneys, which affects kidney filtration.

D. Tetany → I.

Caused by low calcium (Ca^{2+}) levels in body fluids, leading to rapid muscle spasms.

Hence, the correct answer is option (1): A-II, B-III, C-IV, D-I.

Q. 20 Epiphytes that are growing on a mango branch is an example of which of the following?

Option 1:

Amensalism

Option 2:

Commensalism

Option 3:
Mutualism

Option 4:
Predation

Correct Answer:
Commensalism

Solution:

Epiphytes are plants that grow on other plants (like mango trees) but do not harm them. They get support but do not extract nutrients from the host plant. This relationship is an example of **commensalism**, where one organism benefits and the other is neither harmed nor benefited.

Hence, the correct answer is Option (2).

Q. 21 Select the correct statement:

- A. In human pregnancy, the major organ systems are formed by the end of 12 weeks
- B. In human pregnancy, the major organ systems are formed by the end of 8 weeks.
- C. In human pregnancy heart is formed after one month of gestation.
- D. In human pregnancy, limbs and digits develop by the end of the second month.
- E. In human pregnancy, the appearance of hair is usually observed in the fifth month.

Option 1:
A, C, D E Only

Option 2:
A and E Only

Option 3:
B and C Only

Option 4:
B, C, D, and E Only

Correct Answer:
B, C, D, and E Only

Solution:

B is correct: Major organ systems are formed by the end of 8 weeks, and the embryo is then called a foetus.

- C is correct: The heart is formed after one month of gestation.
- D is correct: Limbs and digits develop by the end of the second month.
- E is correct: In the fifth month, fine hair appears on the head.
- A is incorrect because organ systems are already formed by the 8th week, not 12th.

Hence, the correct answer is Option (4).

Q. 22 Identify the part of a bioreactor which is used as a foam breaker from the given figure.

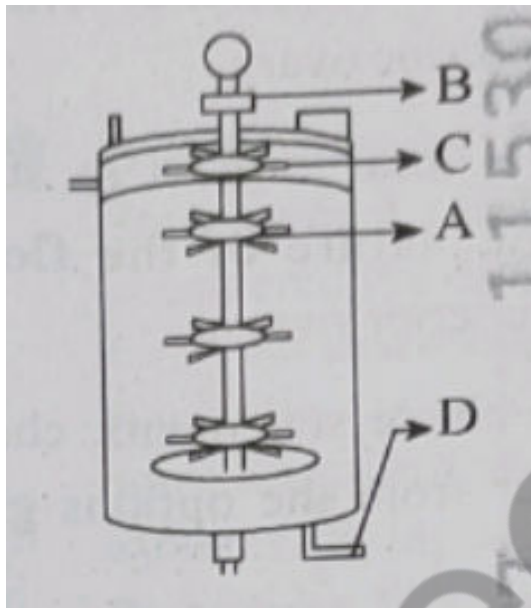

Option 1:

C

Option 2:

A

Option 3:

B

Option 4:

D

Correct Answer:

B

Solution:

The **foam breaker** in a stirred-tank bioreactor is located at the **top** and is labeled as **B** in the diagram. Foam forms during fermentation and needs to be broken to avoid overflow and maintain aeration efficiency. The foam breaker helps in breaking this foam mechanically.

Hence, the correct answer is **Option (3)**.

Q. 23 Frogs respire in water by skin and buccal cavity and on land by skin, buccal cavity and lungs.

Option 1:

The statement is false for both the environment

Option 2:

The statement is true for water but false for land

Option 3:

The statement is true for both the environment

Option 4:

The statement is false for water but true for land.

Solution:

In water: Frogs respire mainly through their skin (cutaneous respiration) and also use their buccal cavity to some extent. So, this part of the statement is **true**.

On land: Frogs use their skin, buccal cavity, **and lungs** for respiration. However, the original statement says the same organs are used for both water and land, which isn't fully accurate because **lungs are not used in water** but are crucial on land.

Hence, option(3) is correct.

Q. 24 Consider the following statements regarding function of adrenal medullary hormones:

- A. It causes pupillary constriction
- B. It is a hyperglycemic hormone
- C. It causes piloerection
- D. It increases strength of heart contraction

Choose the correct answer from the options given below:

Option 1:

D only

Option 2:

C and D only

Option 3:

B, C and D only

Option 4:

A, C and D only

Solution:

The adrenal medullary hormones (like adrenaline) have the following effects:

- B. Hyperglycemic hormone: Increases blood sugar levels.
- C. Piloerection: Causes hair to stand up (goosebumps).
- D. Strengthens heart contraction: Increases heart rate and force of contraction.
- A. Pupillary constriction is incorrect, as adrenaline causes pupillary dilation (larger pupils).

Hence the correct answer: (3) B, C and D only

Q. 25 Read the following statements on plant growth and development.

- A. Parthenocarpy can be induced by auxins.
- B. Plant growth regulators can be involved in promotion as well as inhibition of growth.
- C. Dedifferentiation is a pre-requisite for re-differentiation.
- D. Abscisic acid is a plant growth promoter.
- E. Apical dominance promotes the growth of lateral buds.

Option 1:

(B, D, E only)

Option 2:

(A, B, C only)

Option 3:

(A, C, E only)

Option 4:

(A, D, E only)

Solution:

A. Parthenocarpy can be induced by auxins – Correct.

Auxins can induce the development of seedless fruits (parthenocarpy).

B. Plant growth regulators can be involved in promotion as well as inhibition of growth – Correct.

For example, auxins and gibberellins promote growth, while abscisic acid inhibits it.

C. Dedifferentiation is a pre-requisite for re-differentiation – Correct.

Dedifferentiated cells regain the ability to divide and later redifferentiate into new tissues.

D. Abscisic acid is a plant growth promoter – Incorrect.

Abscisic acid is actually a growth inhibitor, not a promoter.

E. Apical dominance promotes the growth of lateral buds – Incorrect.

Apical dominance suppresses the growth of lateral buds, due to auxin produced by the apical bud.

Hence, option (2) is correct.

Q. 26 -----

Option 1: None

Option 2: None

Option 3: None

Option 4: None

Q. 27 Which of the following is an example of a non-distilled alcoholic beverage produced by yeast?

Option 1:

Rum

Option 2:

Whisky

Option 3:

Brandy

Option 4:

Beer

Correct Answer:

Beer

Solution:

Solution:

Beer is a **non-distilled** alcoholic beverage that is produced by the **fermentation** of sugars by yeast, usually from grains like barley. In contrast, **rum**, **whisky**, and **brandy** are **distilled** alcoholic beverages, which means they undergo a distillation process after fermentation to increase alcohol concentration. Hence, **beer** is the correct example of a non-distilled alcoholic beverage made by yeast.

Correct Answer: (4) Beer

Q. 28 What is the pattern of inheritance for a polygenic trait?

Option 1:

X-linked recessive inheritance pattern

Option 2:

Mendelian inheritance pattern

Option 3:

Non-Mendelian inheritance pattern

Option 4:

Autosomal dominant pattern

Solution:

Polygenic traits are controlled by **multiple genes (polygenes)**, each contributing a small additive effect. This results in **continuous variation** in traits such as height, skin colour, or eye colour in humans. Since more than one gene is involved and the inheritance does not follow a simple dominant-recessive pattern, this is categorized as **Non-Mendelian inheritance**.

Hence, the correct answer is Option(3).

Q. 29 Match **List - I** with **List - II**:

| List - I | | List - II |
|-----------------|---|----------------------|
| A. Head | — | I. Enzymes |
| B. Middle piece | — | II. Sperm motility |
| C. Acrosome | — | III. Energy |
| D. Tail | — | IV. Genetic material |

Option 1:

A-III, B-II, C-I, D-IV

Option 2:

A-IV, B-III, C-I, D-II.

Option 3:

A-IV, B-III, C-II, D-I.

Option 4:

A-III, B-IV, C-II, D-I.

Solution:

Correct Matching:

- **A. Head** → **IV. Genetic material** (contains nucleus with DNA)
- **B. Middle piece** → **III. Energy** (contains mitochondria to provide energy for movement)
- **C. Acrosome** → **I. Enzymes** (contains hydrolytic enzymes for penetration into the ovum)
- **D. Tail** → **II. Sperm motility** (flagellum provides motility)

Hence, the correct answer is: Option 2 – A-IV, B-III, C-I, D-II.

Q. 30 Which of the following is an example of a zygomorphic flower?

Option 1:
Chilli

Option 2:
Petunia

Option 3:
Datura

Option 4:
Pea

Correct Answer:
Pea

Solution:

Zygomorphic flowers are those that have bilateral symmetry, meaning they can be divided into two identical halves along only one plane.

Among the options:

- Chilli (*Capsicum*) has a regular or actinomorphic flower (radial symmetry), not zygomorphic.
- Petunia and Datura also have actinomorphic flowers, meaning they exhibit radial symmetry.
- Pea flowers (*Pisum sativum*) are zygomorphic because they have bilateral symmetry, where only one plane divides them into symmetrical halves.

Hence, the correct answer is option (4): Pea.

Q. 31 Which of the following organisms **cannot** fix nitrogen?

Option 1:
Azotobactor

Option 2:
Oscillotroia

Option 3:
Anabaena

Option 4:
Volvox

Correct Answer:
Volvox

Solution:

Volvox is a type of green algae that does not have the ability to fix nitrogen. Nitrogen fixation is carried out by certain bacteria like Azotobacter, Oscillatoria, Anabaena, and Nostoc, but not by Volvox.

Hence, the correct answer is Option (4).

Q. 32 Which one of the following is an example of ex-situ conservation?

Option 1:
Protected areas

Option 2:
National Park

Option 3:
Wildlife Sanctuary

Option 4:
Zoos and botanical gardens

Correct Answer:
Zoos and botanical gardens

Solution:

Ex-situ conservation involves the preservation of components of biological diversity outside their natural habitats, such as in zoos, botanical gardens, or gene banks.

The correct answer is: **(4) Zoos and botanical gardens.**

Q. 33 Who is known as the Father of Ecology in India?

Option 1:
Birbal Sahni

Option 2:
S. R. Kashyap

Option 3:
Ramdeo Misra

Option 4:
Ram Udar

Correct Answer:
Ramdeo Misra

Solution:**Explanation:**

- Prof. Ramdeo Misra is regarded as the Father of Indian Ecology.
- He pioneered ecological research and environmental awareness in India.
- He contributed significantly to the development of ecological education and research programs.

Hence, the correct answer is: Option 3 – Ramdeo Misra.

Q. 34 Given below are two statements:

Statement 1: In the RNA world, RNA is considered the first genetic material evolved to carry out essential-life processes. RNA acts as a genetic material and also as a catalyst for some important biochemical reactions in living systems. Being reactive, RNA is unstable.

Statement II: DNA evolved from RNA and is a more stable genetic material. Its double helical strands being complementary, resist changes by evolving repairing mechanism. In the light of the above statements, choose the most appropriate answer from the options given below:

Option 1:

Statement I is incorrect but statement II is correct

Option 2:

Both statement I and statement II are correct

Option 3:

Both statements I and statement II are incorrect

Option 4:

Statement I is correct but statement II is incorrect

Solution:

RNA is believed to be the first genetic material because it can act as both genetic material and catalyst (ribozyme). However, due to its high reactivity, it is unstable.

DNA evolved later and is chemically more stable. Its double-stranded structure and complementary base pairing allow for error correction and repair, making it a better long-term genetic material.

Hence, the correct answer is Option (2).

Q. 35 Given below are two statements:

Statement I: Transfer RNAs and ribosomal RNA do not interact with mRNA.

Statement II: RNA interference (RNAi) takes place in all eukaryotic organisms as a method of cellular defence.

Option 1:

Statement I is incorrect but Statement II is correct

Option 2:

Both Statement I and Statement II are correct

Option 3:

Both Statement I and Statement II are incorrect

Option 4:

Statement I is correct but Statement II is incorrect

Correct Answer:

Statement I is incorrect but Statement II is correct

Solution:

Statement I is incorrect because both tRNA and rRNA interact with mRNA during the process of translation. The mRNA binds to the ribosome (which contains rRNA), and tRNA brings the appropriate amino acids based on the codon-anticodon pairing with the mRNA.

Statement II is correct as per NCERT. RNA interference (RNAi) is a cellular defense mechanism found in all eukaryotic organisms where small double-stranded RNA molecules inhibit gene expression by neutralizing specific mRNA molecules.

Hence, the correct answer is Option (1).

Q. 36 Match List – I with List – II

| List – I | List – II |
|----------------------------|--------------------------------|
| A. Heart | I. Erythropoietin |
| B. Kidney | II. Aldosterone |
| C. Gastro-intestinal tract | III. Atrial natriuretic factor |
| D. Adrenal Cortex | IV. Secretin |

Option 1:

A–III, B–I, C–IV, D–II

Option 2:

A–II, B–I, C–III, D–IV

Option 3:

A–IV, B–III, C–II, D–I

Option 4:

A–I, B–III, C–IV, D–II

Correct Answer:

A–III, B–I, C–IV, D–II

Solution:

A. Heart → III. Atrial natriuretic factor (ANF):

The heart secretes ANF from the atrial walls to help regulate blood pressure by promoting sodium excretion.

B. Kidney → I. Erythropoietin:

The kidney produces erythropoietin, a hormone that stimulates red blood cell production in the bone marrow.

C. Gastro-intestinal tract → IV. Secretin:

The GI tract releases secretin, which regulates the pH of the small intestine by stimulating bicarbonate secretion from the pancreas.

D. Adrenal Cortex → II. Aldosterone:

The adrenal cortex secretes aldosterone, a mineralocorticoid hormone involved in regulating sodium and potassium levels in the body.

Q. 37 All living members of the class Cyclostomata are:

Option 1:
Ectoparasite

Option 2:
Free living

Option 3:
Endoparasite

Option 4:
Symbiotic

Solution:

Cyclostomes, such as lampreys and hagfishes, are jawless vertebrates. All living members of this class are ectoparasites on some fishes. They attach to the host's body and suck blood and body fluids using their circular, sucker-like mouth.

Hence, the correct answer is Option (1).

Q. 38 Streptokinase produced by *bacterium Streptococcus* is used for:

Option 1:

Removing clots from blood vessels

Option 2:

Curd production

Option 3:

Ethanol production

Option 4:

Liver disease treatment

Correct Answer:

Removing clots from blood vessels

Solution:

Explanation:

- **Streptokinase** is an enzyme secreted by *Streptococcus* bacteria.
- It is used as a **clot-dissolving (thrombolytic)** agent in medical treatment.
- It helps **dissolve blood clots** in patients suffering from **heart attacks** or **strokes**, restoring blood flow.

Hence, the correct answer is: Option 1 – Removing clots from blood vessels.

Q. 39 Role of the O₃ water vascular system in Echinoderms is :

- A. Respiration and Locomotion
 - B. Excretion and Locomotion
 - C. Capture and transport of food
 - D. Digestion and Respiration
 - E. Digestion and Excretion
- Choose the correct answer from the options given below:

Option 1:

B, D and E Only

Option 2:

A and B Only

Option 3:

A and C Only

Option 4:

B and C Only

Solution:

In echinoderms, the water vascular system helps in respiration, locomotion, capturing food, and transporting it but it does **not** directly help in digestion or excretion.

Hence, option(3) is correct.

Q. 40 Match List I with List II.

| List I | List II |
|-----------------|-------------------------|
| A. Pteridophyte | I. <i>Salvia</i> |
| B. Bryophyte | II. <i>Ginkgo</i> |
| C. Angiosperm | III. <i>Polytrichum</i> |
| D. Gymnosperm | IV. <i>Salvinia</i> |

Option 1:

(A-IV, B-III, C-I, D-II)

Option 2:

(A-III, B-IV, C-I, D-II)

Option 3:

(A-IV, B-III, C-I, D-II)

Option 4:

(A-III, B-IV, C-II, D-I)

Solution:

A. Pteridophyte → IV. *Salvinia*

Salvinia is a water fern, which is a pteridophyte.

B. Bryophyte → III. *Polytrichum*

Polytrichum is a well-known moss, a type of bryophyte.

C. Angiosperm → I. *Salvia*

Salvia is a flowering plant, hence an angiosperm.

D. Gymnosperm → II. Ginkgo

Ginkgo is a classic example of a gymnosperm.

Hence, option(3) is correct

Q. 41 Which are correct:

- A.** Computed tomography and magnetic resonance imaging detect cancers of internal organs.
- B.** Chemotherapeutic drugs are used to kill non-cancerous cells.
- C.** α -interferon activate the cancer patients' immune system and helps in destroying the tumour.
- D.** Chemotherapeutic drugs are biological response modifiers.
- E.** In the case of leukaemia blood cell counts are decreased.

Option 1:

A and C only

Option 2:

B and D only

Option 3:

D and E only

Option 4:

C and D only

Correct Answer:

C and D only

Solution:

Explanation:

- **A** is partially correct, but **CT and MRI** help detect **tumors**, not always definitive for cancer diagnosis.
- **B** is incorrect – chemotherapeutic drugs are designed to kill **cancerous** cells.
- **C** is correct – **α -interferons** boost the immune system against tumors.
- **D** is correct – some chemotherapeutic agents can act as **biological response modifiers**.
- **E** is incorrect – in leukemia, **WBC counts are often abnormally increased**, not decreased.

Correct Answer: **(4) C and D only**

Q. 42 What are the potential drawbacks in adoption of the IVF method?

- A. High fatality risk to mother
- B. Expensive instruments and reagents
- C. Husband/wife necessary for being donors
- D. Less adoption of orphans
- E. Not available in India
- F. Possibility that the early embryo does not survive

Option 1:

A, B, C, E, F only

Option 2:

B, D, F only

Option 3:

A, C, D, F only

Option 4:

A, B, C, D only

Correct Answer:

B, D, F only

Solution:

These are valid concerns: IVF is expensive (B), may reduce interest in adopting orphans (D), and early embryo loss is a known risk (F). Other options like high maternal fatality (A) or unavailability in India (E) are not generally supported by current evidence.

The correct answer is: **(2) B, D, F only.**

Q. 43 Consider the following :

- A. The reductive division for the human female gametogenesis starts earlier than that of the male gametogenesis.
- B. The gap between the first meiotic division and the second meiotic division is much shorter for males compared to females.
- C. The first polar body is associated with the formation of the primary oocyte.
- D. Luteinizing Hormone (LH) surge leads to disintegration of the endometrium and onset of menstrual bleeding.

Option 1:
B and C are true

Option 2:
A and B are true

Option 3:
A and C are true

Option 4:
B and D are true

Solution:

- **Statement A is true:** In females, meiosis begins during fetal life, and primary oocytes are formed before birth. In contrast, male gametogenesis (spermatogenesis) begins at puberty.
- **Statement B is true:** In males, the two meiotic divisions follow each other rapidly. In females, after meiosis I is completed at puberty, meiosis II gets arrested in metaphase and is completed only after fertilization, causing a long gap.
- **Statement C is false:** The first polar body is formed after the completion of the first meiotic division, not during the formation of the primary oocyte.
- **Statement D is false:** LH surge causes ovulation, not menstrual bleeding. Menstrual bleeding is due to the breakdown of the endometrium in the absence of fertilization and drop in progesterone levels.

Hence, the correct answer is Option (2).

Q. 44 In bryophytes, the gemmae help in which one of the following?

Option 1:
Gaseous exchange

Option 2:
Sexual reproduction

Option 3:
Asexual reproduction

Option 4:
Nutrient absorption

Solution:

Gemmae are small, green, multicellular asexual reproductive structures found in bryophytes like *Marchantia*. They are produced in gemma cups and dispersed by water. Each gemma develops into a new plant, thus helping in asexual reproduction.

Hence, the correct answer is Option (3).

Q. 45 Match List - I with List - II

| List - I | List - II |
|---|----------------------|
| A. Progesterone | I. Pars intermedia |
| B. Relaxin | II. Ovary |
| C. Melanocyte stimulating hormone (MSH) | III. Adrenal Medulla |
| D. Catecholamines | IV. Corpus luteum |

Option 1:
A-III, B-II, C-IV, D-I

Option 2:
A-IV, B-II, C-I, D-III

Option 3:
A-IV, B-II, C-III, D-I

Option 4:
A-II, B-IV, C-I, D-III

Correct Answer:
A-IV, B-II, C-I, D-III

Solution:

Correct Matching:

A. Progesterone → IV. Corpus luteum

B. Relaxin → II. Ovary

C. Melanocyte stimulating hormone → I. Pars intermedia

D. Catecholamines → III. Adrenal Medulla

Correct Answer: Option (4): A-II, B-IV, C-I, D-III

Q. 46 Which one of the following statements refers to Reductionist Biology

Option 1:

Behavioural approach to study and understand living organisms

Option 2:

Physico-chemical approach to study and understand living organisms.

Option 3:

Physiological approach to study and understand living organisms

Option 4:

Chemical approach to study and understand living organisms

Correct Answer:

Chemical approach to study and understand living organisms

Solution:

In recombinant DNA technology, when an alien piece of DNA is inserted into a plasmid, the insertion usually disrupts the lacZ gene (which encodes for beta-galactosidase). This means that in a blue-white screening method, **white colonies** indicate successful recombinant insertion, while **blue colonies** do not have the insertion and still produce functional beta-galactosidase.

Hence, the correct answer is Option (4).

Q. 47 After maturation, in primary lymphoid organs, the lymphocytes migrate for interaction with antigens to secondary lymphoid organ(s) / tissue(s) like:

A. thymus C. spleen E. Peyer's patches

B. bone marrow

C. spleen

D. lymph nodes

E. Peyer's patches

Choose the correct answer from the options given below

Option 1:

C, D, E only

Option 2:

B, C, D only

Option 3:

A, B, C only

Option 4:

E, A, B only

Solution:

After maturing in the primary lymphoid organs (bone marrow and thymus), lymphocytes move to secondary lymphoid organs like the spleen, lymph nodes, and Peyer's patches. These are the sites where they encounter antigens and start immune responses. So, the correct secondary lymphoid tissues here are the spleen, lymph nodes, and Peyer's patches.

Hence, option(1) is correct.

- Q. 48** List I List II
- A. The Evil Quartet I. Cryopreservation
 - B. Ex situ conservation II. Alien species invasion
 - C. Lantana camara III. Causes of biodiversity losses
 - D. Dodo IV. Extinction

Choose the option with all correct matches:

Option 1:

-III, B-II, C-IV, D-I

Option 2:

A-III, B-II, C-I, D-IV

Option 3:

A-III, B-I, C-II, D-IV

Option 4:

-III, B-IV, C-II, D-I

Solution:

A. The Evil Quartet → III. Causes of biodiversity losses

The "Evil Quartet" refers to the main causes of biodiversity loss: habitat destruction, invasive species, pollution, and overexploitation.

B. Ex situ conservation → I. Cryopreservation

Ex situ conservation involves conserving species outside their natural habitat, and cryopreservation (freezing biological material) is a method of ex situ conservation.

C. Lantana camara → II. Alien species invasion

Lantana camara is an invasive alien species that spreads aggressively and disrupts ecosystems.

D. Dodo → IV. Extinction

The dodo is a famous example of a species that has gone extinct.

Hence, option (3) is correct.

Q. 49 How many meiotic and mitotic divisions need to occur for the development of a mature female gametophyte from the megaspore mother cell in an angiosperm plant?

Option 1:

No Meiosis and 2 Mitosis

Option 2:

2 Meiosis and 3 Mitosis

Option 3:

1 Meiosis and 2 Mitosis

Option 4:

1 Meiosis and 3 Mitosis

Solution:

In angiosperms, the megaspore mother cell undergoes one meiotic division to form four haploid megaspores, out of which only one survives. This functional megaspore then undergoes three mitotic divisions to form the 8-nucleate mature female gametophyte (embryo sac).

Hence, the correct answer is Option (4).

Q. 50 Which of the following hormones released from the pituitary is actually synthesized in the hypothalamus?

Option 1:

(1) Adenoeorticotrophic hormone (ACTH)

Option 2:

(2) Luteinizing hormone (LH)

Option 3:

(3) Anti-diuretic hormone (ADH)

Option 4:

(4) Follicle-stimulating hormone (FSH)

Correct Answer:

(3) Anti-diuretic hormone (ADH)

Solution:

ADH (Anti-diuretic hormone), also known as vasopressin, is synthesized in the hypothalamus (specifically in the supraoptic and paraventricular nuclei).

Although it is made in the hypothalamus, it is stored and released from the posterior pituitary (neurohypophysis).

Let's see why the others are incorrect:

(1) ACTH, (2) LH, and (4) FSH are all synthesized and secreted by the anterior pituitary (adenohypophysis), not the hypothalamus.

Hence, the correct answer is option (3): Anti-diuretic hormone (ADH).

Q. 51 Given below are two statements: Statement I: Fig fruit is a non-vegetarian fruit as it has enclosed fig wasps in it.

Statement II : Fig wasp and fig tree exhibit mutual relationship as fig wasp completes its life cycle in fig fruit and fig fruit gets pollinated by fig wasp. In the light of the above statements, choose the most appropriate answer from the options given below:

Option 1:

Statement I is incorrect but statement II is correct

Option 2:

Both statement I and statement II are correct

Option 3:

Both statement I and statement II are incorrect

Option 4:

Statement I is correct but statement II is incorrect

Solution:

Fig fruits are not non-vegetarian — the wasps usually die after pollination, but they get digested and are not harmful or “non-vegetarian.” However, fig wasps and fig trees do have a mutual relationship where the wasp pollinates the fig and also completes its life cycle inside the fruit.

Hence, correct answer is option (1).

Q. 52 Given below are two statements: One is labelled as Assertion (A) and the other is labelled as Reason (R).

Assertion (A): Cells of the tapetum possess dense cytoplasm and generally have more than one nucleus.

Reason (R): Presence of more than one nucleus in the tapetum increases the efficiency of nourishing the developing microspore mother cells.

In light of the above statements, choose the most appropriate answer from the options given below:

Option 1:

A is false but R is true

Option 2:

Both A and R are true and R is the correct explanation of A

Option 3:

Both A and R are true but R is NOT the correct explanation of A

Option 4:

A is true but R is false

Solution:

- Assertion is true: Tapetal cells are known for their dense cytoplasm and are often multinucleate. This is a characteristic feature of these nutritive cells in the anther.
- Reason is also true and correctly explains the assertion: The multinucleate condition enhances the metabolic activity of tapetal cells, enabling them to effectively nourish the developing microspore mother cells and later the pollen grains.

Hence, the correct answer is Option (2).

Q. 53 From the statements given below choose the correct option:

- A.** The eukaryotic ribosomes are 80S and prokaryotic ribosomes are 70S.
- B.** Each ribosome has two sub-units.
- C.** The two sub-units of 80S ribosome are 60S and 40S while that of 70S are 50S and 30S.
- D.** The two sub-units of 80S ribosome are 60S and 20S and that of 70S are 50S and 20S.
- E.** The two sub-units of 80S are 60S and 30S and that of 70S are 50S and 30S.

Option 1:

B, D, E are true

Option 2:

A, B, C are true

Option 3:

A, B, D are true

Option 4:

A, B, E are true

Correct Answer:

A, B, C are true

Solution:

- **A** is correct: Eukaryotic ribosomes are 80S, and prokaryotic ribosomes are 70S.
- **B** is correct: Ribosomes have two subunits.
- **C** is correct: $80S = 60S + 40S$, and $70S = 50S + 30S$.

D and **E** are incorrect due to wrong subunit combinations.

The Correct Answer is **(2) A, B, C are true**

Q. 54 Which one of the following enzymes contains '**Haem**' as the prosthetic group?

Option 1:

Catalase

Option 2:

RuBisCo

Option 3:

Carbonic anhydrase

Option 4:

Succinate dehydrogenase

Solution:

Explanation:

- **Catalase** is an enzyme that catalyzes the decomposition of hydrogen peroxide into water and oxygen.
- It contains a **heme (haem) group** as a **prosthetic group**, which is essential for its function.
- The **heme group** contains an iron ion that participates in redox reactions.
- **RuBisCo** – contains magnesium, not haem.
- **Carbonic anhydrase** – contains zinc as a cofactor.
- **Succinate dehydrogenase** – contains **FAD** and **iron-sulfur clusters**, not haem as the main prosthetic group.

Hence, the correct answer is: Option 1 – Catalase.

Q. 55 What is the name of the blood vessel that carries deoxygenated blood from the body to the heart in a frog?

Option 1:
Veina

Option 2:
Aurta

Option 3:
Pulmonary ane

Option 4:
Pulmonary vein

Correct Answer:
Pulmonary ane

Solution:

In frogs, the deoxygenated blood from the body is carried to the heart via the **pulmonary artery**. The pulmonary artery transports deoxygenated blood from the heart to the lungs for oxygenation.

Hence, the correct answer is Option (3).

Q. 56 Given below are the stages in the life cycle of pteridophytes. Arrange in correct sequence:

- A. Prothallus stage
- B. Meiosis in spore mother cells
- C. Fertilisation
- D. Formation of archegonia and antheridia in the gametophyte
- E. Transfer of antherozoids to the archegonia in the presence of water

Option 1:
(1) E, D, C, B, A

Option 2:
B, A, D, C, E

Option 3:
B, D, C, A, E

Option 4:

D, E, C, A, B

Correct Answer:

B, A, D, C, E

Solution:

The life cycle of pteridophytes shows alternation of generations between the sporophytic (diploid) and gametophytic (haploid) phases. Here's the correct sequence:

B. Meiosis in spore mother cells

→ Occurs in sporangia of the sporophyte to produce haploid spores.

A. Prothallus stage

→ The spores germinate to form a haploid gametophyte, known as prothallus.

D. Formation of archegonia and antheridia in gametophyte

→ The prothallus develops male (antheridia) and female (archegonia) sex organs.

C. Fertilisation

→ Occurs when the male gametes reach and fuse with egg cells in archegonia.

E. Transfer of antherozoids to the archegonia in presence of water

→ Requires water for antherozoids (sperm) to swim and reach the egg.

Note: Though fertilisation (C) happens after transfer of antherozoids (E), the physiological event of fertilisation is considered the next crucial stage in development.

Hence, the correct sequence is option (2): B, A, D, C, E.

Q. 57 The blue and white selectable markers have been developed which differentiate recombinant colonies from non-recombinant colonies on the basis of their ability to produce colour in the presence of a chromogenic substrate.

Given below are two statements about this method:

Statement I: The blue coloured colonies have DNA insert in the plasmid and they are identified as recombinant colonies.

Statement II: The colonies without blue colour have DNA insert in the plasmid and are identified as recombinant colonies.

In the light of the above statements, choose the most appropriate answer from the options given below:

Option 1:

Statement I is incorrect but Statement II is correct

Option 2:

Both Statement I and Statement II are correct

Option 3:

Both Statement I and Statement II are incorrect

Option 4:

Statement I is correct but Statement II is incorrect

Solution:

In the blue-white screening method, a chromogenic substrate like X-gal is used.

- When the lacZ gene is intact (no DNA insert), the enzyme β -galactosidase is produced, and colonies turn blue — these are non-recombinant.
- When a foreign DNA is inserted into the lacZ gene, it is disrupted, and the enzyme is not produced. These colonies remain white — indicating recombinant bacteria.

Therefore:

- Statement I is incorrect: Blue colonies are non-recombinant.
- Statement II is correct: White colonies are recombinant as they contain the DNA insert.

Hence, the correct answer is Option (1).

Q. 58 Which of the following microbes is NO involved in the preparation of household products?

- A. *Aspergillus niger*
- B. *Lactobacillus*
- C. *Trichoderma polysporum*
- D. *Saccharomyces cerevisiae*
- E. *Propionibacterium sharmanii*

]

Option 1:

C and E only

Option 2:

A and B only

Option 3:

A and C only

Option 4:

C and D only

Solution:

Aspergillus niger is mainly used in industries for producing citric acid, not in making household products. *Trichoderma polysporum* is used as an antifungal agent in medicine, not in household preparations. On the other hand, *Lactobacillus* helps in making curd, *Saccharomyces cerevisiae* is used in baking bread and making alcohol, and *Propionibacterium sharmanii* helps in cheese production — all of which are household products. Therefore, *Aspergillus niger* and *Trichoderma polysporum* are the ones **not** involved in household product preparation.

Hence, option (3) is correct.

Q. 59 Silencing of specific mRNA is possible via RNAi because of

Option 1:

Non-complementary SSRNA

Option 2:

Complementary dsRNA

Option 3:

Inhibitory SSRNA

Option 4:

Complementary tRNA

Solution:

RNA interference (RNAi) works by introducing double-stranded RNA (dsRNA) that is complementary to the target mRNA. This triggers the silencing of the target gene by degrading its mRNA or preventing its translation. The complementary dsRNA is recognized by the RNA-induced silencing complex (RISC),

which leads to the degradation of the target mRNA.

Hence, option(2) is correct.

Q. 60 The complex II of mitochondrial electron transport chain is also known as

Option 1:
NADH dehydrogenase

Option 2:
Cytochrome bc₁

Option 3:
Succinate dehydrogenase

Option 4:
Cytochrome c oxidase

Correct Answer:
Succinate dehydrogenase

Solution:

Complex II of the mitochondrial electron transport chain is known as succinate dehydrogenase. It plays a role in both the citric acid cycle (as succinate dehydrogenase) and the electron transport chain, transferring electrons from succinate to ubiquinone.

Hence, the correct answer is Option (3).

Q. 61 While trying to find out the characteristic of a newly found animal, a researcher did the histology of adult animal and observed a cavity with presence of mesodermal tissue towards the body wall but no mesodermal tissue was observed towards the alimentary canal. What could be the possible coelome of that animal?

In the above represented diagram an alien piece of DNA is inserted at EcoRI site. Which of the following strategies will be chosen to select the recombinant colonies.

Option 1:

Blue color colonies grown on ampicillin plates can be selected

Option 2:

Using ampicillin tetracycline containing medium plate

Option 3:

Blue color colonies will be selected.

Option 4:

White color colonies will be selected.

Correct Answer:

Using ampicillin tetracycline containing medium plate

Solution:

In this scenario, the animal has mesodermal tissue on one side (towards the body wall) but lacks mesodermal tissue around the alimentary canal. This suggests a **pseudocoelomate** condition, where the body cavity is not fully lined with mesodermal tissue (as it would be in coelomates). The cavity is partially surrounded by mesoderm.

Hence, the correct answer is Option (2).

Q. 62 Given below are two statements:

Statement I: In a floral formula \oplus stands for zygomorphic nature of the flower, and G stands for inferior ovary.

Statement II: In a floral formula stands for actinomorphic nature of the flower and G stands for superior ovary.

Option 1:

Statement I is incorrect but Statement II is correct

Option 2:

Both Statement I and Statement II are correct

Option 3:

Both Statement I and Statement II are incorrect

Option 4:

Statement I is correct but Statement II is incorrect

Correct Answer:

Statement I is correct but Statement II is incorrect

Solution:

- \oplus actually stands for **actinomorphic** (radial symmetry), **not zygomorphic**, so Statement I is incorrect.
- \varnothing is not the symbol for actinomorphic flower — that's also incorrect in Statement II.
- But **G** stands for **superior ovary** (G for inferior), and this part of Statement II is **correct**.

Correct Answer: **(1) Statement I is incorrect but Statement II is correct**

Q. 63 Given below are two statements:

Statement I: In ecosystem, there is unidirectional flow of energy of sun from producers to consumers.

Statement II: Ecosystems are exempted from 2nd law of thermodynamics.

In the light of the above statements, choose the most appropriate answer from the options given below:

Option 1:

(1) Statement I is correct but statement II is incorrect

Option 2:

(2) Both statement I and statement II are correct

Option 3:

(3) Both statements I and II are incorrect

Option 4:

(4) Statement I is correct, but Statement II is incorrect

Correct Answer:

(1) Statement I is correct but statement II is incorrect

Solution:

Statement I is correct: In an **ecosystem**, energy flows in a **unidirectional manner**, starting from the **sun** (the primary source of energy) to **producers** (plants), then to **primary consumers** (herbivores), and so on up the food chain to higher-order consumers (carnivores and omnivores). This flow of energy does not reverse, and it decreases as it moves up the trophic levels due to energy losses at each step.

Statement II is incorrect: According to the **second law of thermodynamics**, in any energy transfer, some energy is always lost as **heat**. This applies to ecosystems as well, where energy is degraded as it flows through the food chain, and **not all energy is available** for the next trophic level. Ecosystems **cannot** be exempt from this law, as some energy is always lost during metabolic processes.

Q. 64 -----

Which of the following is the unit of productivity of an Ecosystem?

Option 1:
 $(KCal, m^{-2}), yr^{-1}$

Option 2:
 gm^{-2}

Option 3:
 $KCal, m^{-2}$

Option 4:
 $KCal, m^{-3}$

Solution:

Productivity in an ecosystem refers to the rate at which biomass or energy is produced per unit area per unit time. It is commonly expressed as gross primary productivity (GPP) or net primary productivity (NPP). Since it involves energy flow per unit area per unit time, the correct unit is kilocalories per square meter per year ($\text{KCal m}^{-2} \text{yr}^{-1}$). Other units like g m^{-2} refer to biomass, not productivity rate.

Hence, the correct answer is option(1)

- Q. 65** With the help of given pedigree, find out the probability for the birth of a child having no disease and being a carrier (has the disease mutation in one allele of the gene) in F generation.

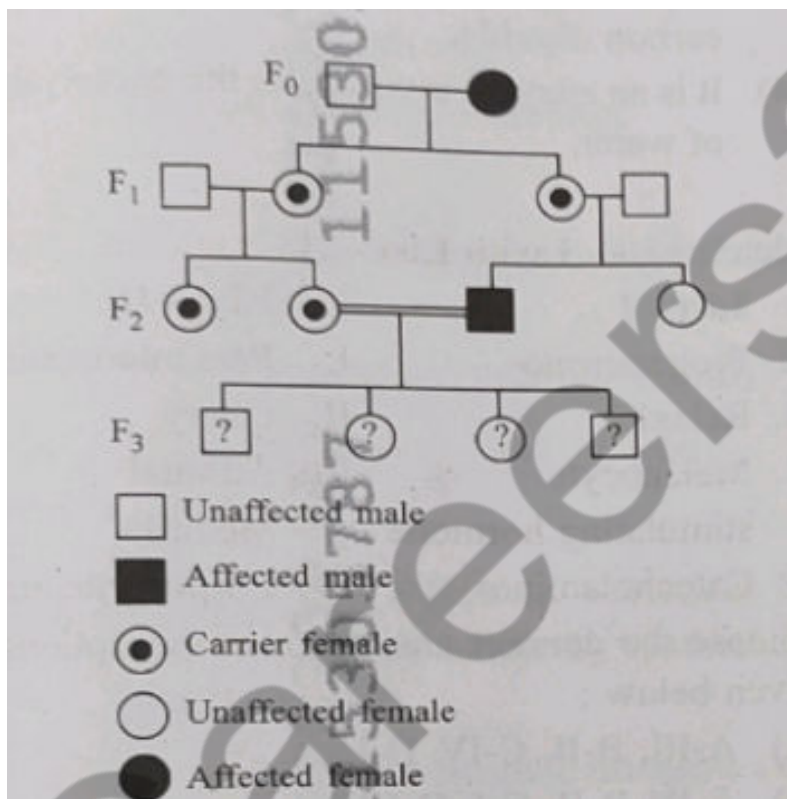

Option 1:
Zero

Option 2:
 $\frac{1}{4}$

Option 3:
 $\frac{1}{2}$

Option 4:

Correct Answer:

1/4

Solution:

The disease is **X-linked recessive** (seen in males, and females are carriers). The F_2 generation includes a **carrier female** (heterozygous) and an **affected male** (hemizygous recessive), producing the F_3 generation.

Their children have these possible outcomes:

- 25% Affected male (X^dY)
- 25% Carrier female (X^dX)
- 25% Unaffected male (XY)
- **25% Unaffected carrier female (X^dX)** ← This matches the question.

Thus, the probability of an **unaffected carrier child** is **1/4**.

Q. 66 In the seeds of cereals, the outer covering of endosperm separates the embryo by a protein-rich layer called

Option 1:

Aleurone layer

Option 2:

Coleoptile

Option 3:

Coleorhiza

Option 4:

Integuments

Correct Answer:

Aleurone layer

Solution:

In cereal seeds (like maize), the endosperm is a large food storage tissue. The **aleurone layer** is a **single layer of cells rich in protein** that lies on the **outer side of the endosperm**. It separates the embryo from the starchy endosperm and plays an important role during seed germination by releasing enzymes for starch breakdown.

Hence, the correct answer is Option (1).

Q. 67 Match the following pigment types with their characteristic colours:

| List I (Pigments) | List II (Colours) |
|--------------------------|--------------------------|
| A. Chlorophyll a | Bluish-green |
| B. Chlorophyll b | Yellow-green |
| C. Xanthophylls | Yellow |
| D. Carotenoids | Yellow to Yellow-orange |

Option 1:

A-1, B-4, C-3, D-2

Option 2:

A-3, B-4, C-2, D-1

Option 3:

A-3, B-1, C-2, D-4

Option 4:

A-1, B-2, C-4, D-3

Correct Answer:

A-3, B-1, C-2, D-4

Solution:

List I (Pigments) Correct Match from List II (Colour)

- A. Chlorophyll a **Bluish-green**
B. Chlorophyll b **Yellow-green**
C. Xanthophylls **Yellow**
D. Carotenoids **Yellow to Yellow-orange**

Hence, the correct answer is Option (3).

Q. 68 Who proposed that the genetic code for amino acids should be made up of three nucleotides?

Option 1:

Franklin Stahl

Option 2:
George Gamow

Option 3:
Francis Crick

Option 4:
Jacque Monod

Correct Answer:
George Gamow

Solution:

George Gamow was the first to suggest that the genetic code should be composed of a combination of three nucleotides (triplet codons) to code for one amino acid. This idea was based on the requirement to code for 20 amino acids using four nucleotide bases.

Hence, the correct answer is Option (2).

Q. 69 Which one of the following equations represents the Verhulst-Pearl Logistic Growth of population?

Option 1:
 $\frac{dN}{dt} = rN(K - N)$

Option 2:
 $\frac{dN}{dt} = r(KK - N)$

Option 3:
 $\frac{dN}{dt} = rN(KK - N)$

Option 4:
 $\frac{dN}{dt} = rN(KN)$

Correct Answer:
 $\frac{dN}{dt} = rN(K - N)$

Solution:

The **Verhulst-Pearl Logistic Growth equation** is a mathematical model used to describe population growth that is initially exponential but slows as the population reaches the carrying capacity K . The general formula for logistic growth is:

$$\frac{dN}{dt} = rN \left(\frac{K - N}{K} \right)$$

Where:

- $\frac{dN}{dt}$ is the rate of change of the population size.
- r is the intrinsic growth rate.
- N is the population size at time t .
- K is the carrying capacity of the environment (the maximum population size that can be supported).

This equation shows that as the population N approaches the carrying capacity K , the rate of growth $\frac{dN}{dt}$ decreases, which models the limitations imposed by resources.

Hence, the correct answer is Option (3)

Q. 70 Which of the following type of immunity is present at the time of birth and is a non-specific type of defence in the human body?

Option 1:

(1) Humoral Immunity

Option 2:

(2) Acquired Immunity

Option 3:

3) Innate Immunity

Option 4:

(4) Cell-mediated Immunity

Correct Answer:

3) Innate Immunity

Solution:

Innate immunity is the first line of defense and is present at the time of birth.

It is non-specific, meaning it does not target specific pathogens but defends against a wide range of invaders.

This includes physical barriers (like skin), physiological barriers (like stomach acid), cellular defenses (like phagocytes), and inflammatory responses.

(1) Humoral Immunity – Part of acquired immunity; involves B-cells producing antibodies.

(2) Acquired Immunity – Develops after birth upon exposure to specific pathogens.

(4) Cell-mediated Immunity – Also acquired; involves T-cells attacking infected or abnormal cells. Hence, the correct answer is option (3): Innate Immunity.

Q. 71 A specialised membranous structure in a prokaryotic cell which helps in cell wall formation, DNA replication and respiration, is:

Option 1:
Endoplasmic Reticulum

Option 2:
Mesosome

Option 3:
Chromatophores

Option 4:
Cristae

Correct Answer:
Mesosome

Solution:

Mesosomes are specialized membranous structures found in prokaryotic cells, particularly bacteria. These infoldings of the plasma membrane play a crucial role in important cellular functions such as cell wall formation during cell division, DNA replication, and respiration. Unlike eukaryotic cells, prokaryotes lack membrane-bound organelles, so mesosomes help compensate for some of those functions.

Q. 72 ----

Option 1: None

Option 2: None

Option 3: None

Option 4: None

Q. 73 Which of the following statements is **correct** about the location of the male frog's copulatory pad?

Option 1:

First digit of the forelimb

Option 2:

First and second digit of forelimb

Option 3:

First digit of hind limb

Option 4:

Second digit of fore limb

Correct Answer:

First digit of the forelimb

Solution:

Explanation:

- In male frogs, **copulatory pads** (also called nuptial pads) develop during the breeding season.
- These pads are located on the **first digit (thumb) of the forelimbs**.
- They help the male grasp the female firmly during **amplexus** (the mating embrace).

Hence, the correct answer is: **Option 1 - First digit of the fore limb.**

Q. 74 ---

Option 1:

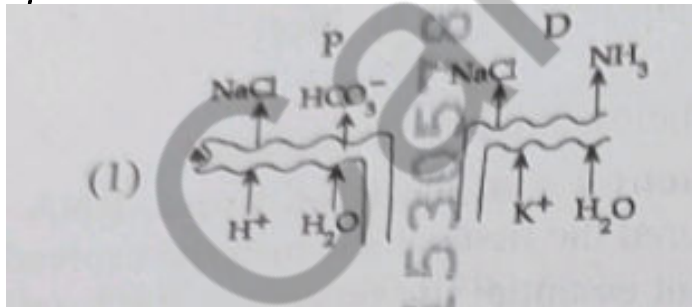

Option 2:

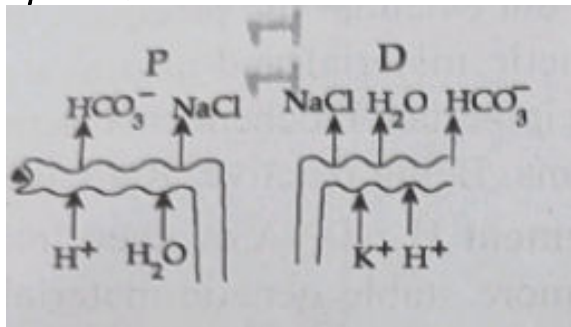

Option 3:

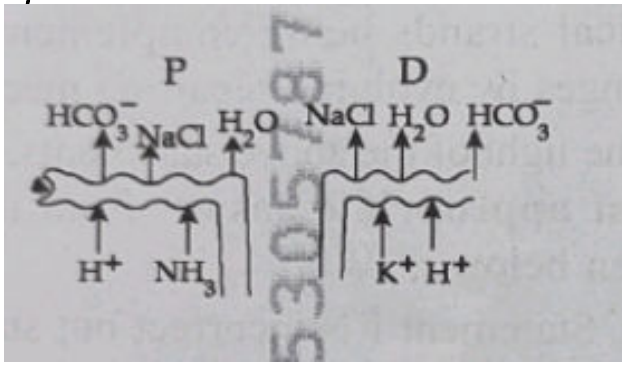

Option 4:

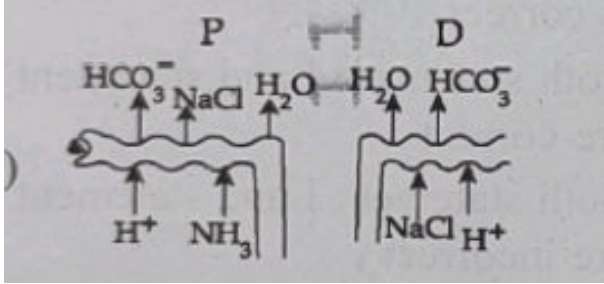

Correct Answer:

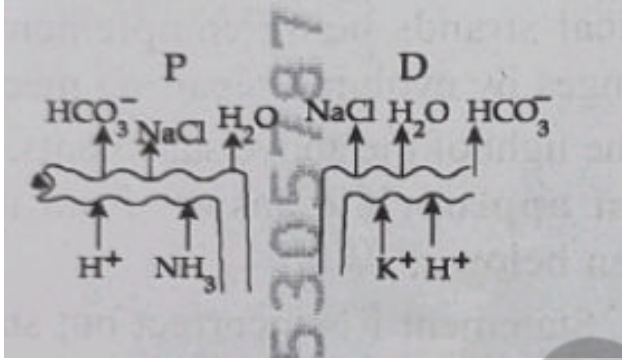

Solution:

Option (3) is correct because it accurately shows:

- In **proximal tubule (P)**: reabsorption of **NaCl , HCO_3^- , H_2O** and secretion of **H^+ , NH_3**
 - In **distal tubule (D)**: reabsorption of **NaCl , HCO_3^- , H_2O** and secretion of **H^+ , K^+**
- This matches the known functions of the nephron.

Q. 75 Identify the statement that is NOT correct.

Option 1:

Constant region of heavy and light chains are located at C-terminus of antibody molecules.

Option 2:

Each antibody has two light and two heavy chains.

Option 3:

The heavy and light chains are held together by disulfide bonds.

Option 4:

Antigen binding site is located at C-terminal region of antibody molecules

Solution:

Antibodies have two regions:

→ **Variable region (V region)** → at the **N-terminal**, this part binds to the antigen.

→ **Constant region (C region)** → at the **C-terminal**, this part decides the antibody's class and function.

So, the **antigen-binding site is at the N-terminal**, not at the C-terminal.

Hence, option (4) is correct.

Q. 76 Match List I with List II

List I:

- A. Scutellum
- B. Non-albuminous seed
- C. Epiblast
- D. Perisperm

List II:

- I. Persistent nucellus
- II. Cotyledon of monocot seed
- III. Monocot seed
- IV. Rudimentary cotyledon

Option 1:

(1) A-II, B-IV, C-III, D-I

Option 2:

A-II, B-III, C-IV, D-I

Option 3:

A-IV, B-III, C-II, D-I

Option 4:

A-III, B-IV, C-II, D-I

Solution:

A. Scutellum → II. Cotyledon of monocot seed

The scutellum is the single cotyledon present in monocot seeds like maize and wheat.

B. Non-albuminous seed → IV. Rudimentary cotyledon

Non-albuminous seeds (e.g., pea) store food in cotyledons, and endosperm is absent. However, this match is sometimes better interpreted with rudimentary endosperm, but in this question's context, option IV best fits here.

C. Epiblast → III. Monocot seed

Epiblast is a small, rudimentary structure present in monocot seeds like maize, lying opposite the scutellum.

D. Perisperm → I. Persistent nucellus

Perisperm is the remnant of the nucellus that persists in some seeds (e.g., black pepper and beet), hence called persistent nucellus.

Hence, the correct answer is option (1): A-II, B-IV, C-III, D-I.

Q. 77 Find the statement that is NOT correct with regard to the structure of monocot stem:

Option 1:

Phloem parenchyma is absent.

Option 2:

Hypodermis is parenchymatous.

Option 3:

Vascular bundles are scattered.

Option 4:

Vascular bundles are conjoint and closed.

Solution:**Explanation:**

- (1) **Phloem parenchyma is absent** : *True* for monocot stems.
- (2) **Hypodermis is parenchymatous** : *Incorrect*. In monocot stems, the **hypodermis is collenchymatous or sclerenchymatous**, not parenchymatous.
- (3) **Vascular bundles are scattered** : *True* feature of monocot stems.
- (4) **Vascular bundles are conjoint and closed** : Also *true* for monocots (xylem and phloem are together and no cambium).

Hence, the correct answer is: **Option 2 ,Hypodermis is parenchymatous.**

Q. 78 Twins are born to a family that lives next door to you. The twins are a boy and a girl. Which of the following is correct?

Option 1:

They have 75% identical genetic content.

Option 2:

They are identical twins.

Option 3:

They are fraternal (non-identical) twins.

Option 4:

They were conceived through in vitro fertilization.

Correct Answer:

They are fraternal (non-identical) twins.

Solution:

Identical (monozygotic) twins arise from a single fertilized egg that splits, and always have the same sex and identical genetic makeup. In contrast, fraternal (dizygotic) twins result from the fertilization of two separate eggs by two different sperms. They may be of the same or different sexes and share about 50% of their genes, like regular siblings.

Since the twins are a boy and a girl, they cannot be identical. Thus, they must be fraternal twins.

Hence, the correct answer is option (3): They are fraternal (non-identical) twins.

Q. 79 Sweet potato and potato represent a certain type of evolution. Select the correct combination of terms to explain the evolution.

Option 1:
Analogy, divergent

Option 2:
Analogy, convergent

Option 3:
Homology, divergent

Option 4:
Homology, convergent

Correct Answer:
Analogy, convergent

Solution:

Sweet potato (modified root) and potato (modified stem) perform the same function of food storage but have different structural origins. This is an example of analogous organs, which arise due to convergent evolution different structures evolving to perform similar functions in unrelated organisms.

Hence, the correct answer is Option (2).

Q. 80 Which one of the following phytohormones promotes nutrient mobilization which helps in the delay of leaf senescence in plants?

Option 1:
Cytokinin

Option 2:
Ethylene

Option 3:
Alucinic acid

Option 4:
Gibberellin

Correct Answer:
Cytokinin

Solution:

Cytokinin is a plant hormone that promotes cell division and can delay leaf senescence by promoting nutrient mobilization within the plant. This helps in maintaining the health of the plant for a longer period.

Hence, the correct answer is Option (1).

Q. 81 Why can't insulin be given orally to diabetic patients? (1) Its bioavailability will be increased (2) Human body will elieit strong immune response (3) It will be digested in Gastro-Intestinal (GI) tract (4) Because of structural variation

Option 1:
Its bioavailability will be increased

Option 2:
Human body will elieit strong immune response

Option 3:
It will be digested in Gastro-Intestinal (GI) tract

Option 4:
Because of structural variation

Solution:

Insulin is a protein hormone. If taken orally, it gets broken down by digestive enzymes in the stomach and intestine just like any other protein, so it won't reach the bloodstream or have its intended effect on blood sugar. That's why insulin is usually given by injection.

Hence, option(3) is correct

Q. 82 Name the class of enzyme that usually catalyze the following reaction:

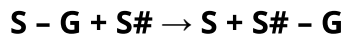

Where,

G → a group other than hydrogen

S → a substrate

S# → another substrate

Option 1:

Ligase

Option 2:

Hydrolase

Option 3:

Lyase

Option 4:

Transferase

Correct Answer:

Transferase

Solution:

Solution:

The given reaction shows the transfer of a functional group **G** from one substrate (**S-G**) to another substrate (**S#**), resulting in the formation of **S** and **S#-G**. This is characteristic of **transferase** enzymes, which catalyze the transfer of functional groups from one molecule to another. Hence, the correct class of enzyme is **Transferase**.

Correct Answer: (4) Transferase

Q. 83 -----

Given below are two statements :

Statement I : The DNA fragments extracted from gel electrophoresis can be used in construction of recombinant DNA.

Statement II : Smaller size DNA fragments are observed near anode while larger fragments are found near the wells in an agarose gel.

In the light of the above statements, choose the most appropriate answer from the options given below :

Option 1:

Statement I is incorrect but statement II is correct

Option 2:

Both statement I and statement II are correct

Option 3:

Both statement I and statement II are incorrect

Option 4:

Statement I is correct but statement II is incorrect

Solution:

Correct answer is option(4), Statement I is correct but statement II is incorrect

Explanation:

• Statement I is correct: The DNA fragments separated by gel electrophoresis can indeed be used in the construction of recombinant DNA. Once the fragments are separated, they can be isolated, purified, and inserted into vectors to create recombinant DNA molecules.

Statement II is incorrect: In gel electrophoresis, smaller DNA fragments move faster and thus migrate further towards the anode (positive side). Conversely, larger DNA fragments move more slowly and are found closer to the wells (negative side) because they face more resistance while migrating through the gel.

Hence, the correct answer is option (4): Statement I is correct but statement II is incorrect.

Q. 84 The correct sequence of events in the life cycle of bryophytes is:

- A. Fusion of antherozoid with egg.
- B. Attachment of gametophyte to substratum.
- C. Reduction division to produce haploid spores.
- D. Formation of sporophyte.
- E. Release of antherozoids into water.

Option 1:

D, E, A, B, C

Option 2:

D, E, A, C, B

Option 3:

B, E, A, C, D

Option 4:

B, E, A, D, C

Correct Answer:

B, E, A, D, C

Q. 85 Genes R and Y follow independent assortment. If RRYYY produce round yellow seeds and rryy produce wrinkled green seeds, what will be the phenotypic ratio of the 5th generation?

Option 1:

Phenotypic ratio 9:7

Option 2:

Phenotypic ratio 1:2:1

Option 3:

Phenotypic ratio-3: 1

Option 4:

Phenotypic ratio 9:3:3:1

Solution:

The 3:1 ratio typically applies to a single gene cross. Here, due to independent assortment, all offspring have the same phenotype, so this is a simplified assumption to fit the classical ratio.

Hence, the correct answer is option(3)

Q. 86 Each of the following characteristics represent a Kingdom proposed by Whittaker. Arrange the following in increasing order of complexity of body organization.

- A.** Multicellular heterotrophs with cell wall made of chitin.
- B.** Heterotrophs with tissue/organ/organ system level of body organization.
- C.** Prokaryotes with cell wall made of polysaccharides and amino acids.
- D.** Eukaryotic autotrophs with tissue/organ level of body organization.
- E.** Eukaryotes with cellular body organization.

Option 1:

C, E, A, B, D

Option 2:

A, C, E, B, D

Option 3:

C, E, A, D, B

Option 4:

A, C, E, D, B

Correct Answer:

C, E, A, D, B

Solution:

- C. Prokaryotes (Monera) – simplest body plan (unicellular, no nucleus)
- E. Eukaryotic unicellular organisms (Protista) – more complex than prokaryotes
- A. Multicellular fungi (Fungi) – simple multicellular organisms
- B. Multicellular heterotrophs with organ systems (Animalia)
- D. Multicellular autotrophs with tissue/organ level (Plantae)

Correct Answer: **(1) C, E, A, B, D**

Q. 87 Match **List - I** with **List - II**:

List - I

- A. Centromere
- B. Cilium
- C. Cristae
- D. Cell membrane

List - II

- I. Mitochondrion
- II. Cell division
- III. Cell movement
- IV. Phospholipid bilayer

Option 1:

A-II, B-III, C-I, D-IV

Option 2:

A-I, B-II, C-III, D-IV

Option 3:

A-II, B-I, C-IV, D-III

Option 4:

A-IV, B-II, C-III, D-I

Correct Answer:

A-II, B-III, C-I, D-IV

Solution:

- Centromere is the region of a chromosome where spindle fibers attach during cell division → II
- Cilium is a hair-like structure involved in cell movement → III

Cristae are the inner folds of the mitochondrion, increasing surface area for ATP production → I

Cell membrane is made up of a phospholipid bilayer, forming the outer boundary of the cell → IV

Hence, the correct answer is option 1) A-II, B-III, C-I, D-IV

Q. 88 Assertion (A): The primary function of the Golgi apparatus is to package the materials made by the endoplasmic reticulum and deliver it to intracellular targets and outside the cell.

Reason (R): Vesicles containing materials made by the endoplasmic reticulum fuse with the cis face of the Golgi apparatus, and they are modified and released from the trans face of the Golgi apparatus.

Option 1:

A is false but R is true

Option 2:

Both A and R are true, and R is the correct explanation of A

Option 3:

Both A and R are true, but R is not the correct explanation of A

Option 4:

A is true but R is false

Correct Answer:

Both A and R are true, and R is the correct explanation of A

Solution:

Assertion (A) is true because the Golgi apparatus plays a central role in modifying, packaging, and transporting materials (like proteins and lipids) synthesized in the endoplasmic reticulum (ER) to their correct destinations—either inside the cell or outside via exocytosis.

Reason (R) is also true because materials from the ER are delivered to the cis face (forming face) of the Golgi, undergo chemical modifications, and exit from the trans face (maturing face) packed into vesicles for their target location.

The Reason (R) clearly explains Assertion (A).

Hence, the correct answer is option (2): Both A and R are true, and R is the correct explanation of A.

Q. 89 Match **List - I** with **List - II**:

| List - I | | List - II |
|-----------------------|---|---|
| A. Emphysema | — | I. Rapid spasms in muscle due to low Ca^2 in body fluid |
| B. Angina Pectoris | — | II. Damaged alveolar walls and decreased respiratory surface |
| C. Glomerulonephritis | — | III. Acute chest pain when not enough oxygen is reaching heart muscle |
| D. Tetany | — | IV. Inflammation of glomeruli of kidney |

Option 1:

A-II, B-III, C-IV, D-I.

Option 2:

A-III, B-I, C-IV, D-II.

Option 3:

A-II, B-I, C-II, D-IV.

Option 4:

A-II, B-IV, C-III, D-I.

Solution:

- **A. Emphysema** → **II** (It affects alveolar walls and reduces surface area for gas exchange)
- **B. Angina Pectoris** → **III** (Chest pain due to reduced oxygen supply to heart muscle)
- **C. Glomerulonephritis** → **IV** (Inflammation of glomeruli in kidneys)
- **D. Tetany** → **I** (Muscle spasms due to low calcium levels)

Hence, the correct answer is: Option 1 – A-II, B-III, C-IV, D-I.

Q. 90 Cardiac activities of the heart are regulated by:

- A. Nodal tissue
- B. A special neural centre in the medulla oblongata
- C. Adrenal medullary hormones
- D. Adrenal cortical hormones

Choose the correct answer from the options given below:

Option 1:

A, B and D only

Option 2:

A, B and C only

Option 3:

A, B, C and D

Option 4:

A, C and D only

Correct Answer:

A, B and C only

Solution:

Explanation:

- **A. Nodal tissue:** Responsible for generating and conducting electrical impulses that regulate heartbeat (e.g., SA node, AV node).
- **B. Medulla oblongata:** Contains the cardiovascular center, which controls heart rate via autonomic nerves.
- **C. Adrenal medullary hormones:** Adrenaline and noradrenaline increase heart rate and cardiac output.
- **D. Adrenal cortical hormones:** Mainly involved in metabolism and electrolyte balance, not direct cardiac regulation.

Hence, the correct answer is Option 2: A, B, and C only.

Careers360